



P-100

MURPHY BED KIT

FULL // VERTICAL

WARNING!

DO NOT DEVIATE FROM THESE PLANS.

ALL MURPHY/WALL BED SYSTEMS CONTAIN STORED ENERGY. FAILURE TO USE AND FOLLOW THESE INSTRUCTIONS DURING THE INSTALLATION PROCESS COULD RESULT IN SEVERE PERSONAL INJURY TO THE USER OR DAMAGE TO PRODUCT. PLEASE CONTACT CUSTOMER SERVICE AT 866-725-6401 FOR ANY QUESTIONS.



WARNING! FAILURE TO FOLLOW THESE INSTRUCTIONS COULD CAUSE SEVERE PERSONAL INJURY OR DEATH. CALL TECHNICAL SUPPORT AT 866-725-6401 IF YOU HAVE ANY QUESTIONS.

DO NOT DEVIATE FROM THESE PLANS.

SECTION 1:

BEFORE GETTING STARTED

Cabinet Material

IT IS STRONGLY RECOMMENDED TO CONSTRUCT WALL BED CABINET USING 4' X 8' PLY CORE (FURNITURE GRADE) PANELS. MDF MAY BE USED BUT BED MAY BE HEAVY TO OPERATE. **PARTICLE BOARD CANNOT BE USED FOR THIS PROJECT.**



RECOMMENDED

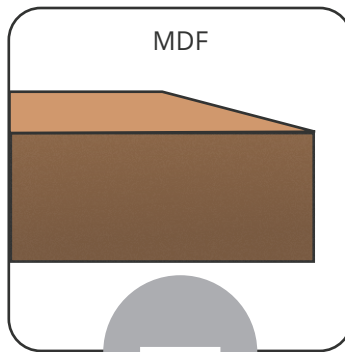

NOT RECOMMENDED

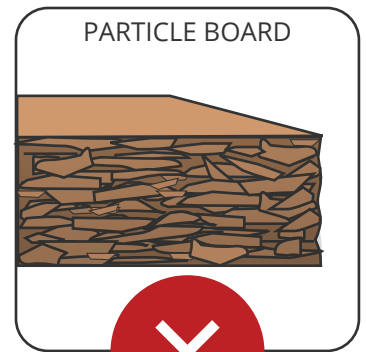

UNSUITABLE

Project Steps

1. Cut, Mill and Edge band all bed cabinetry parts as detailed in these instructions.
2. Apply finish as desired to all cabinet parts as indicated in these instructions.
3. Final Assemble the Murphy bed in the room it is to be used.
4. Anchor cabinetry (bed cabinet) to structural members (i.e. wood studs) in your wall.
5. Familiarize yourself with all of the mechanism components.
6. Install lift mechanism to the bed rails and cabinetry parts as illustrated in these instructions.

Recommended Tools

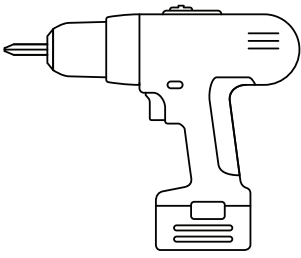

Cordless power drill with Phillips and square tip bits.

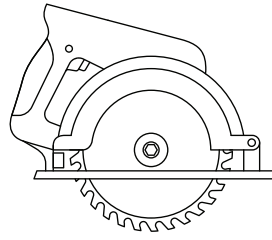

Circular saw with guide
or
Table saw
(Recommended)

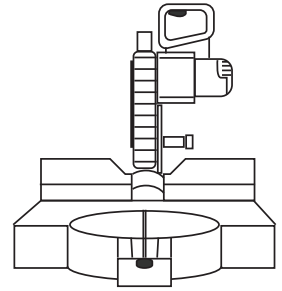

Chop saw or
hand miter saw

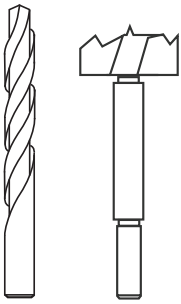

Drill bit set and
Forstner bit sizes:
5/8", 3/4", 1"

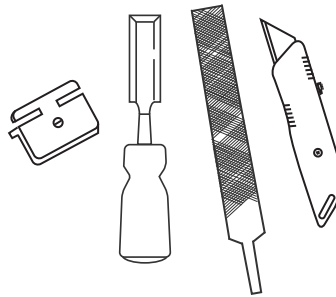

Razor knife, file,
chisel, or edge band
trimmer.

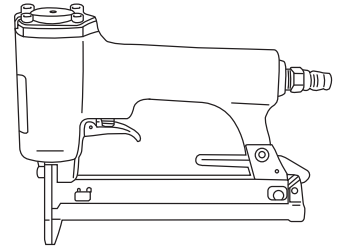

18 ga. brad nail gun
with 1.25" brad nails

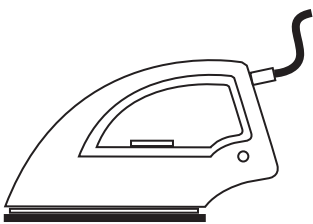

Clothes iron

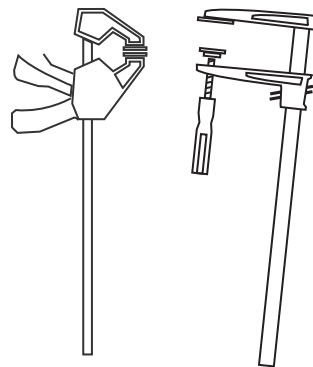

72" bar clamp and
assorted wood clamps.

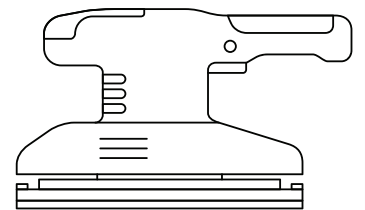

Power sander with
150 or 180 grit
sand paper.

Mechanism Box Contents

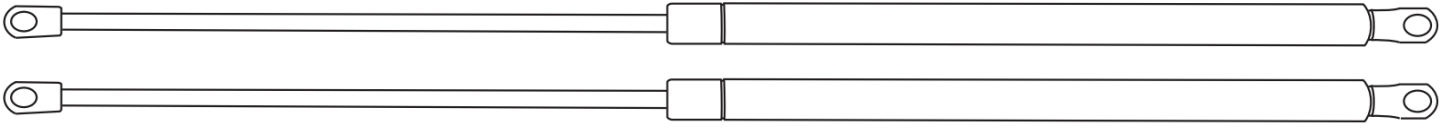

LIFTING PISTONS (2)

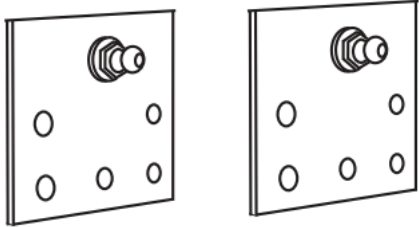

UPPER ANCHOR PLATES (2)

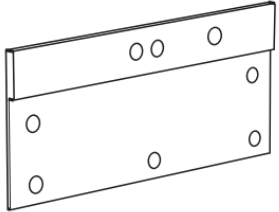

LEFT ANCHOR PLATE

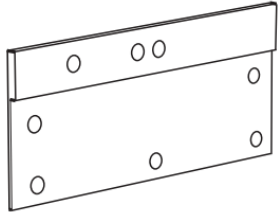

RIGHT ANCHOR PLATE

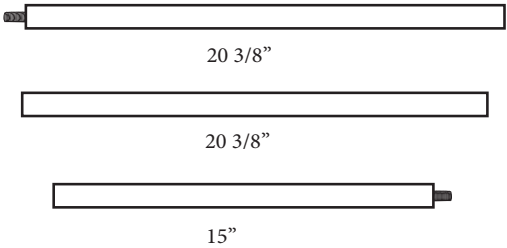

SEGMENTED LEG BARS

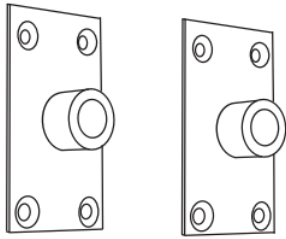

PIVOT HOLE PLATES (2)

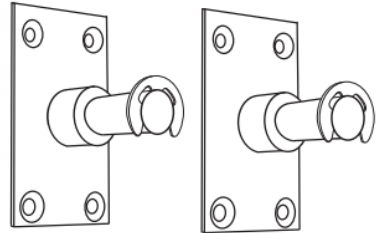

PIVOT POSTS W/ E-CLIPS (2)

HARDWARE CARD #4

1-3/4" X 3/4" X 3/4" LEG STOPS (2)

W 4.2 X 16 PAN HEAD SCREWS (4)

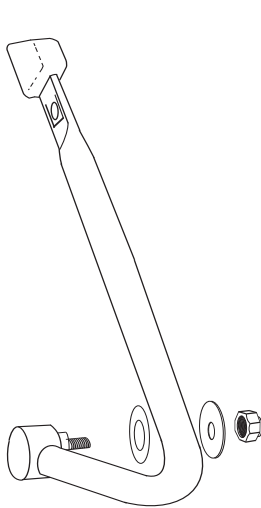

RIGHT LEG W/ HARDWARE

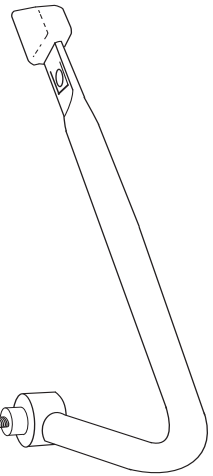





LEFT LEG W/ HARDWARE

Mechanism Box Contents (cont.)

Hardware Card #1

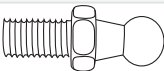
Quantity	Item	Purpose	Image
6	M5 x 35 Machine Screw	Attaching Mechanism to Bed Parts	
6	M5 x 16 Machine Screw	Attaching Mechanism to Bed Parts	
12	M5 Barrel Nut	Attaching Mechanism to Bed Parts	
4	W4.2 x 37 Wood Screw	Attaching Mechanism to Bed Parts	
12	W4.8 x 19 Wood Screw	Attaching Mechanism to Bed Parts	
8	W4.2 x 18 Wood Screw	Attaching Mechanism to Bed Parts	

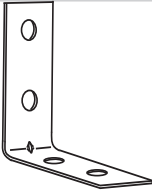
Hardware Card #2

Quantity	Item	Purpose	Image
2	Ball Stud	Attach to Lower Anchor Plates	
2	1/4" Star Washers	Attaching Leg Rod to Legs	
2	M5 x 40 Machine Screw	Attaching Leg Rod to Legs	
3	2" X 2" "L" Brackets	Attaching Bed Cabinet to Studs in Wall	
6	W4.5 X 64 Wood Screw	Attaching Bed Cabinet to Studs in Wall	
6	W4.2 x 16 Pan Head Screw	Attaching Bed Cabinet to Studs in Wall	
1	Warning Label Sticker	Adhere to the top of the Bridge Board	

Hardware Card #3

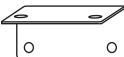
Quantity	Item	Purpose	Image
56	W4.2 x 16 Pan Head Screw	Assembling Bed Cabinet	
14	1-3/4" X 1" X 1" Corner Bracket	Assembling Bed Cabinet	

Items to Source Locally

Quantity	Item
4 sheets	4' X 8' Furniture Grade Plywood Panels MDF may be used but not recommended due to weight and strength. Particle board cannot be used in the construction of this project.
5 pcs. hardwood	4" W X 52.5" L - Mattress Supports
24 linear feet	Hardwood for 3/4" X 3/4" Wood Cleats (for assembling the mattress box)
Solid wood	As desired to add trim work to bed face for style and decoration. Sourced to match plywood panels
150 feet	13/16" Pre glued - Iron on Edge Tape sourced to match wood type
300	1 - 1/4 Countersink Wood Screws
15	2-1/2" Wood Screws
Assorted	Sandpaper as desired
Bottle	Wood Glue
Finishing supplies	Stain, Lacquer, or polyurethane as desired
Bed handles	As desired

SECTION 2:

CUT LISTS

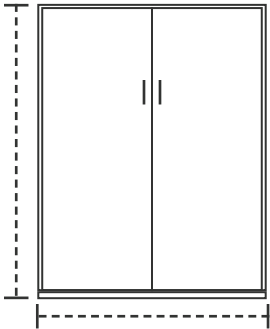

Finished Cabinet Dimensions

59 1/2" W x 83 1/4" H x 16" D

Protrusion from wall: 81 1/2"

Cabinet material: 3/4" ply core or MDF

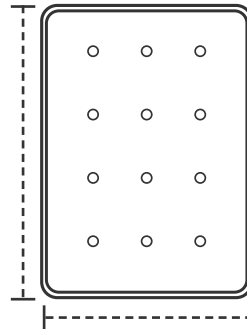

Mattress size

54" W x 75" L

Maximum thickness: 12"

Weight range: 45-80 lb.



BEFORE BEGINNING, ASSESS YOUR TOOL SELECTION AND YOUR SKILL LEVEL. IF YOU DO NOT POSSESS THE PROPER TOOLS, SAFETY EQUIPMENT, OR THE NECESSARY SKILLS, DO NOT PROCEED WITH THIS PROJECT.

GETTING YOUR PANELS CUT FOR YOU:

Many big box stores (i.e. Lowe's or Home Depot) offer cutting panels as a paid service. Check your local lumber yard, big box store, or hardware store to see if this is an option.

If you decide to have your panels cut for you, the following cut sheets and plans will be a critical guide to take to the store with you.

Plywood / MDF Panel Cut List

Quantity	Description	Width	Length	Edge Banding
4 OR 2	Bed face panels Bed face panels	14 3/8" 28 3/4"	78 1/4"	All 4 edges
2	Side Boards	16"	83 1/4"	One long edge (front)
1	Headboard	16"	58"	One long edge (top)
1	Bridge Board	14 1/2"	58"	None
1	Top Fascia	1 3/4"	58"	One long edge (bottom)
1	Front Stretcher	3 1/4"	58"	One long edge (top)
2	Side Rails	4 1/2"	75"	One long edge (top)
1	Head Rail	4 1/2"	55 1/2"	One long edge (top) and both ends
1	Foot Rail	4 1/2"	55 1/2"	One long edge (top) and both ends
2	Mechanism Support	6 1/2"	4 1/2"	One long edge (top) and one short edge

Solid Wood Cut List

Quantity	Item	Width	Description
5	Stiffeners	4" W x 3/4" thick x 52 1/2" L	Solid wood - Used to mend face panels and support mattress
2	Side rail cleats	3/4" x 3/4" x 75" long	Solid wood - Used to attach Side Rails to Face Panels.
1	Head rail cleats	3/4" x 3/4" x 52 1/2" long	Solid wood - Used to attach Head Rail to Face Panels.
1	Foot rail cleats	3/4" x 3/4" x 52 1/2" long	Solid wood - Used to attach Foot Rail to Face Panels.
As desired	Trim pieces		Trim pieces to add style and decorations to face panels
As desired	Crown molding	Crown Mold 10' Long	Trim pieces to add style and decorations to top of cabinet (optional)
As desired	Base molding	Base Mold 10' Long- 4" Max height	Trim Pieces to add style and decorations to base of cabinet (optional)

Planning Your Cuts

NOTE:

Many local hardware stores or lumber yards offer panel cutting as a paid service. Check your local stores to see if that option is available.

SUGGESTED PANEL LAYOUT USING 4' X 8' SHEETS

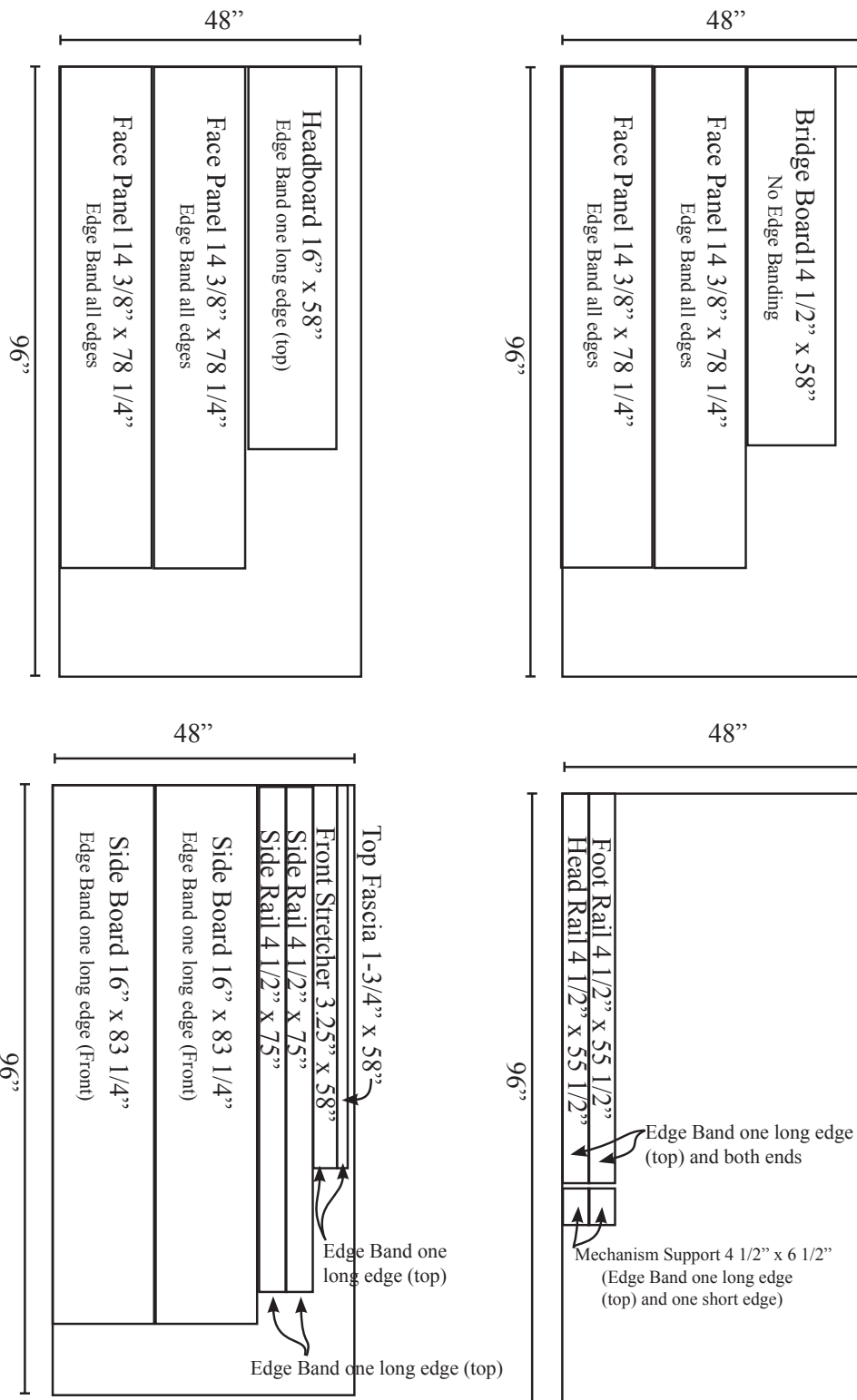

Edge Banding

Headboard 16" x 58"
Edge Band one long edge (top)

Face Panel 14 3/8" x 78 1/4"
Edge Band all edges

Face Panel 14 3/8" x 78 1/4"
Edge Band all edges

Bridge Board 14 1/2" x 58"
No Edge Banding

Face Panel 14 3/8" x 78 1/4"
Edge Band all edges

Face Panel 14 3/8" x 78 1/4"
Edge Band all edges

Side Board 16" x 83 1/4"
Edge Band one long edge (Front)

Side Board 16" x 83 1/4"
Edge Band one long edge (Front)

Top Fascia 1-3/4" x 58"
Edge Band one long edge (top)

Front Stretcher 3 1/4" x 58"
Edge Band one long edge (top)

Side Rail 4 1/2" x 75"
Edge Band one long edge (top)

Side Rail 4 1/2" x 75"
Edge Band one long edge (top)

Foot Rail 4 1/2" x 55 1/2"
Edge Band one long edge (top)
and both ends

Head Rail 4 1/2" x 55 1/2"
Edge Band one long edge (top)
and both ends

Mechanism Support 4 1/2" x 6 1/2"
(Edge Band one long edge (top)
and one short edge)



① APPLYING & TRIMMING EDGE BANDING

Trimming edge banding can be simple and can be done without any specialized tools.

Learn more about how to apply and trim edge banding.

www.wallbedsbywilding.com/how-to-use-edge-banding/



SECTION 3:

BUILDING YOUR BED

Step
1

Preparing Side Rails

As illustrated, Drill holes through the two Side Rails providing for the Lift Mechanisms and Legs. Note the Side Rails mirror each other and it is recommended to drill from the outside of the Side Rails to achieve the most accurate hole pattern.

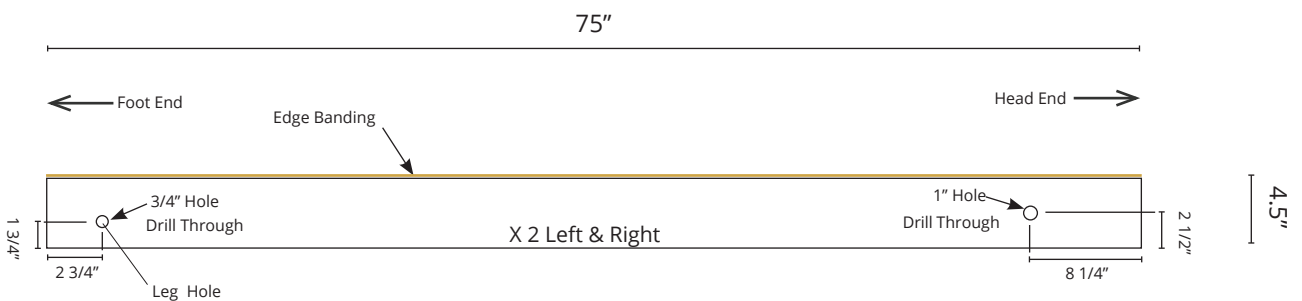
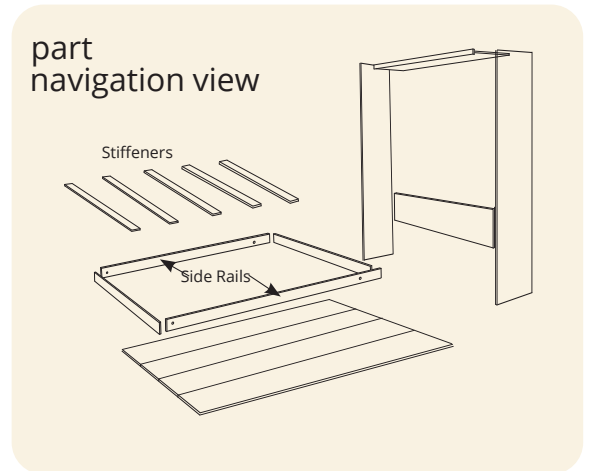

Step
2

Preparing Cleats & Stiffeners

CLEATS:

With a 3/16" Drill Bit drill holes approximately 4" apart in the Head, Foot Rail Cleats and Side Rails Cleats

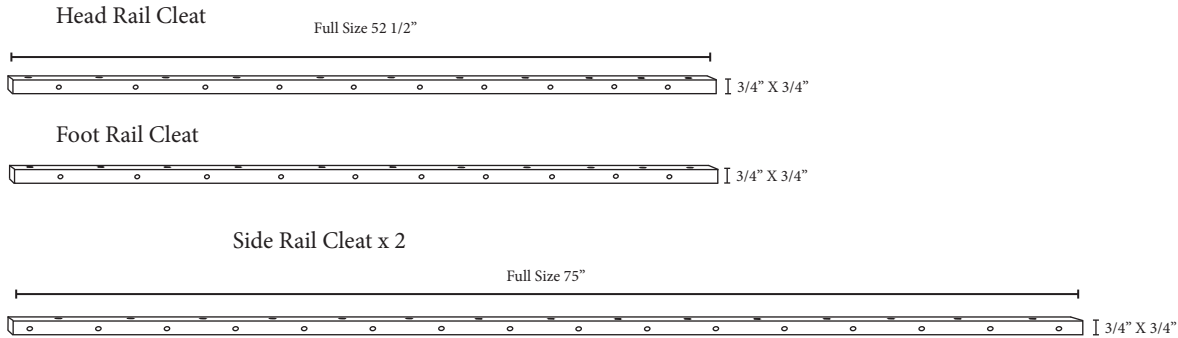

STIFFENERS"

With a 3/16" Drill Bit drill two rows of holes approximately 4" apart in the Stiffeners as illustrated

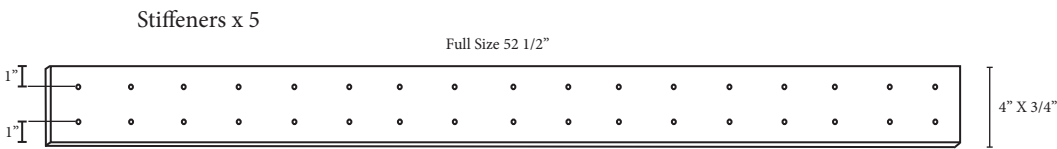

Step 3

Finish Preparing Side, Head, & Foot Rails

NOTE:

Pinning the Cleats in place with Brad Nails after gluing will help with accuracy and ease.

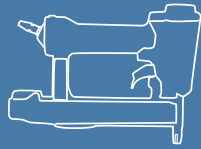

Attach the Side Rail Cleats to the inside bottom of the Side Rails using wood glue and 1-1/4" wood screws through the holes in the Cleats. The bottoms of the Cleats and Side Rails should be flush.

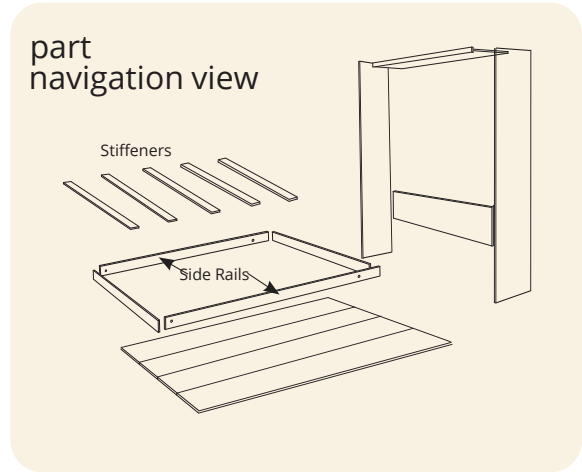

! COMMON ERROR:
Verify the Cleat is attached to the bottom of the Side Rail by verifying these dimensions.

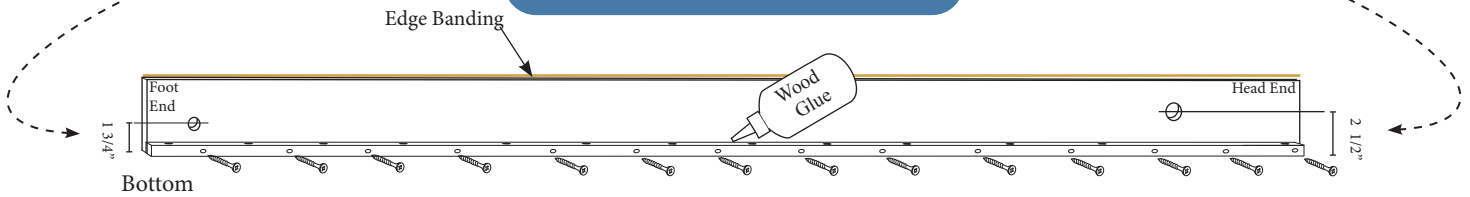

Center the Head and Foot Rail Cleats on the Rails - inside bottom - now attach using wood glue and 1-1/4" wood screws through the holes in the Cleats. The bottom of the Cleats and Head/Foot Rails should be flush.

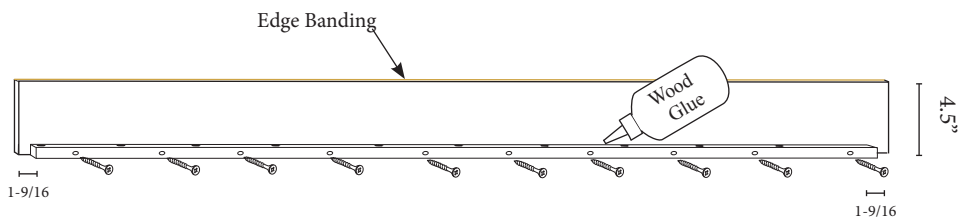
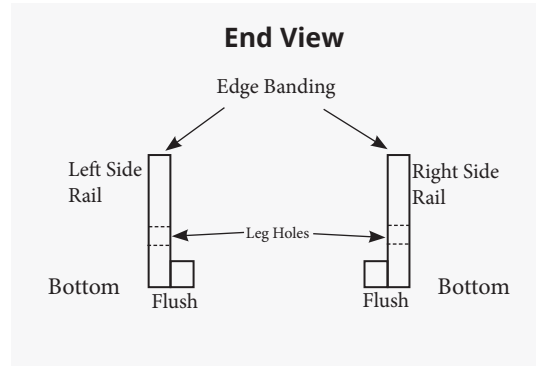

Step 4

Assembling Face Panels & Side Rails

Lay out Face Panels **good sides down** on a flat surface. Face Panels will be the front of the Wall Bed when the bed is closed. Best grain, overall appearance and match will be important so chose the sides, grain pattern etc that suits you best.

Align the Face Panels with each other very carefully making sure the ends are even with each other and that the Panels are pushed together. We recommend using a bar clamp to hold the Face Panels in position.

With the Face Panels square, and pushed together position the Head Rail (Head Rail and Foot Rail are identical) at the head end (head end refers to the end the sleeper's head will rest while bed is in use) of the Face Panels.

The Head Rail should be 3/4" back from the ends of the Face Panels and centered evenly. The Head Rail should be short of each side of the Face Panels by 1".

Once the Head Rail is positioned, use wood glue between the Cleat and Face Panels tack it in place with 1 -1/4" Brad nails to hold its position, then use 1-1/4" wood screws to secure it to the Face Panels.

NOTE:

Pinning the Cleats in place with Brad Nails after gluing will help with accuracy and ease.

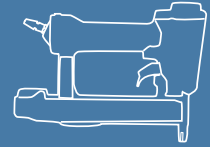

All Face Panel edges should be edge banded

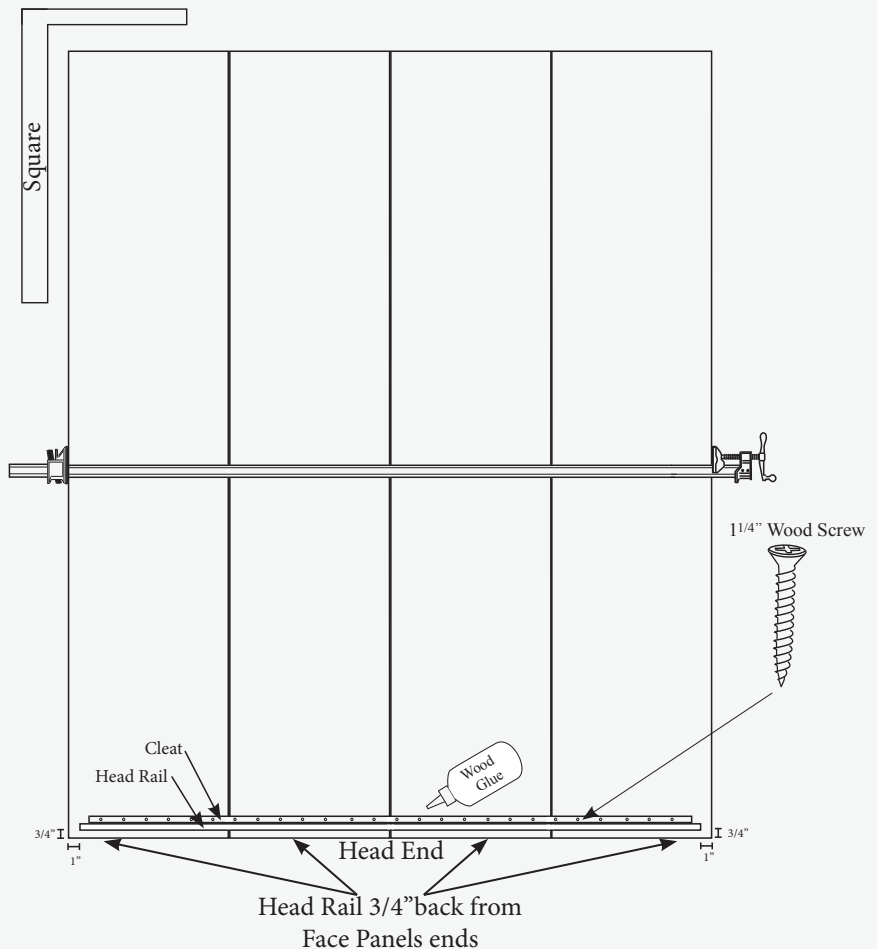

Step 5

Assembling Face Panels & Side Rails (cont.)

Using wood glue and 1-1/4" wood screws attach the left and right Side Rails, Foot Rail, and Stiffeners as illustrated below. Dry fit the Rails to verify fit then start by attaching the left and right Side Rails and insure there remains 1" spacing Head to Foot. Then install the Foot rail between the Side Rails. There should be a 1" reveal of the Face Panels. Lastly install the Stiffeners to the face Panels with the first Stiffener near the Foot Rail and the remaining Stiffeners spaced evenly. Its best to apply wood glue to the Cleats to prevent glue from oozing on to the edge of the Face Panels.

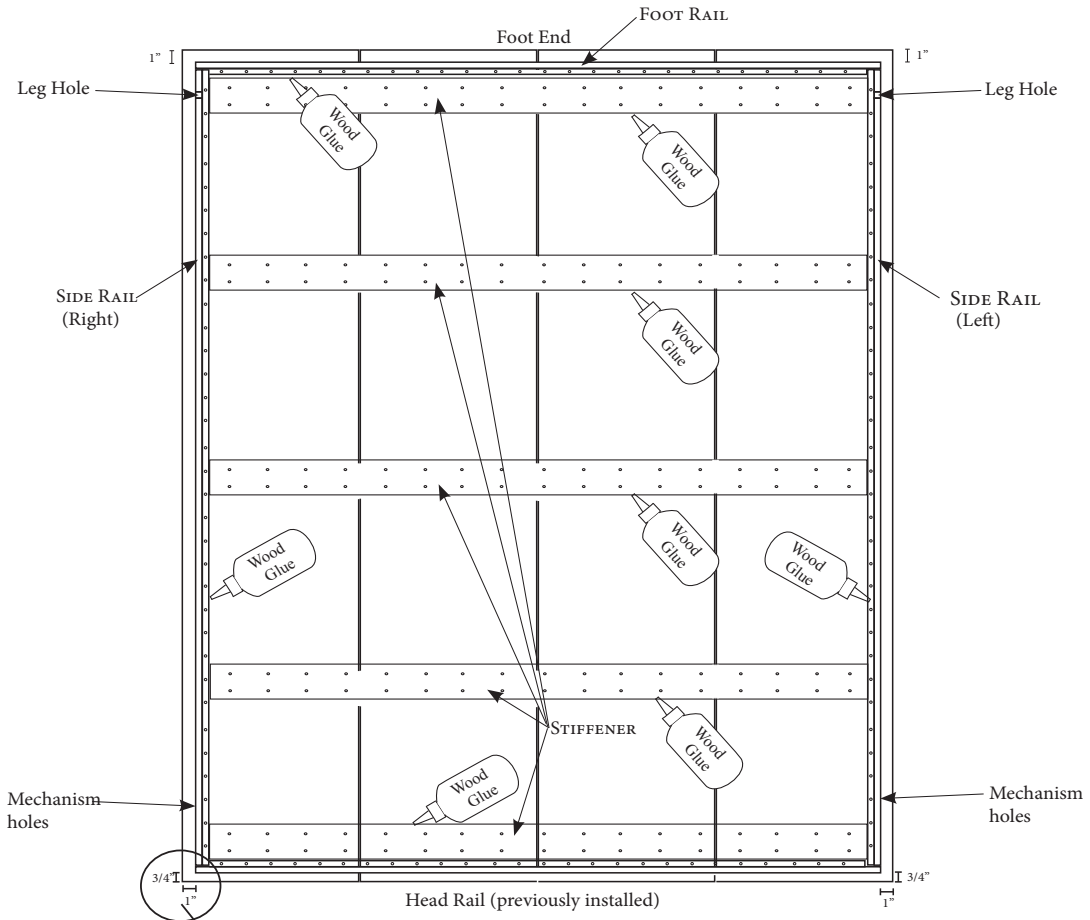

NOTE:
To avoid other screws that will be used in following steps, place the screw in this position.

Screw ALL the corners of the Bed Box together by pre-drilling 9/64" holes to 2" deep through the Head and Foot Rails and into the Side rails then use 2 1/2" wood screws in the pre-drilled holes.

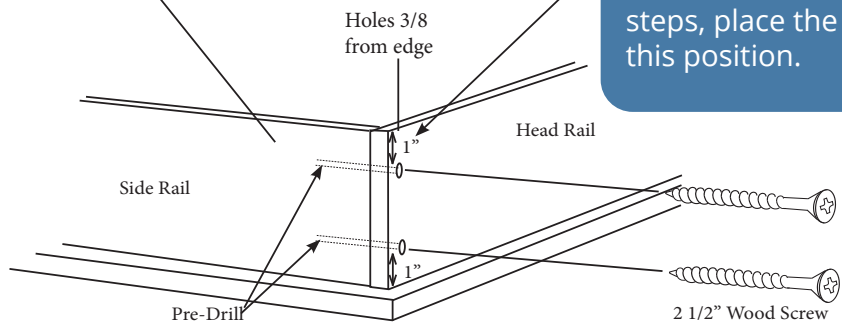

Step 6

Mechanism Supports

Drill 4 through holes in the Mechanism support using a 3/16" Drill bit as illustrated.

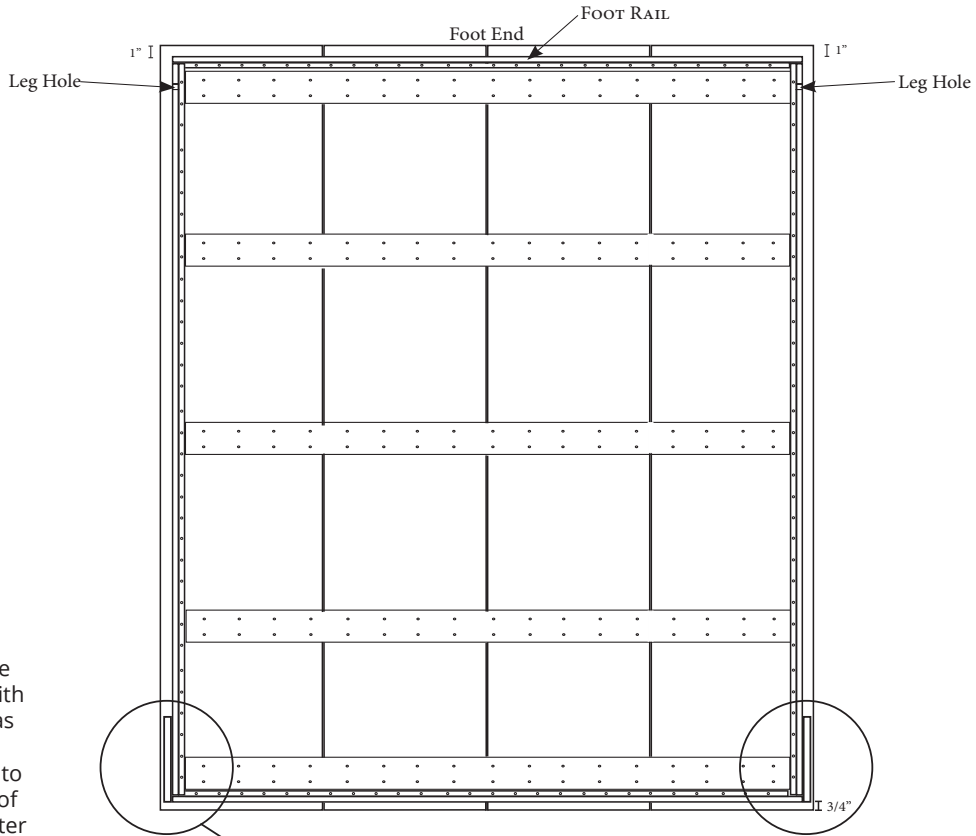
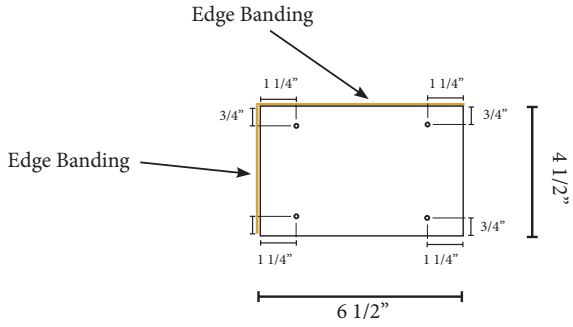

Position Mechanism Supports on the outside of the Side Rails at the Head End of the Bed Box on both sides. It is important that the Mechanism Supports are flush with the Head Rail and Side Rail tops as illustrated. Glue them in position and use four 1 1/4" wood screws to anchor them in place. The head of the wood screws should be counter sunk just enough so they are flush with the surface of the Mechanism Supports.

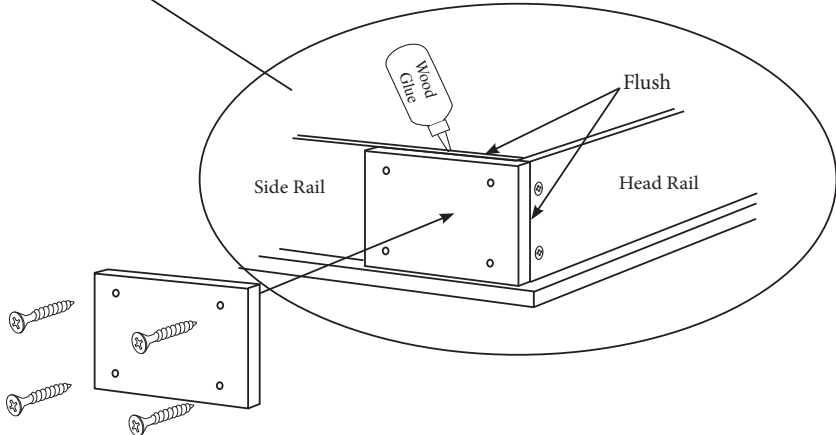

**Step
7**

Mechanism Supports (cont.)

From the Hardware Box, locate one of the Lower Anchor plates.

NOTE:
There is a left and right plate but it will be used only as a template of correct hole placement so either plate will do for now.

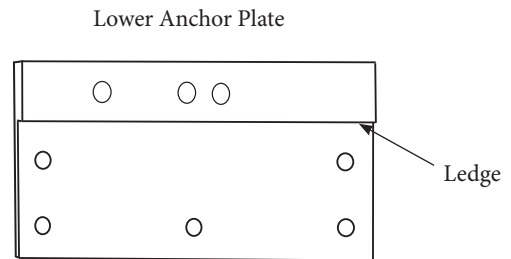

Place the Lower Anchor Plate with its ledge resting on the Mechanism Support and FLUSH to the end of the Bed Box. Using the three interior holes of the Anchor Plate as a template first drill through the Mechanism support and Side Rail with a 13/64" drill bit. Then remove the Anchor Plate and final drill with a 1/4" drill bit for proper hole size.

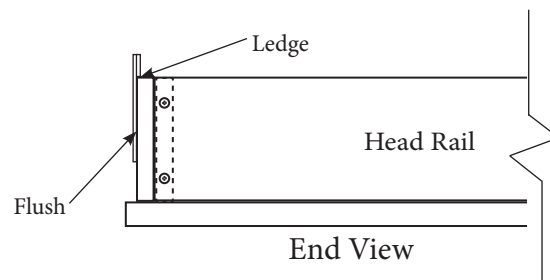
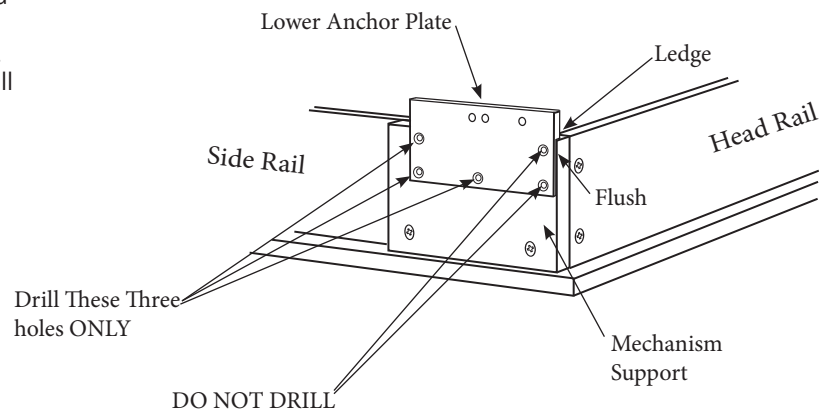

Repeat on the opposite side of the Bed Box. Then place Lower Anchor Plate back in the box to be installed later

Step 8

Milling Side Boards for Lift Mechanisms

Drill holes for Lift Mechanisms in the Side Boards (mirror holes for left and right Side Boards) by marking exact hole location on the inside side of each Side Board using illustration below. Then use a 5/8" Forstner drill bit for the two holes below as illustrated.

NOTE:
HOLES ARE ONLY 5/8" DEEP

Right Side Board illustrated
(Inside panel side)

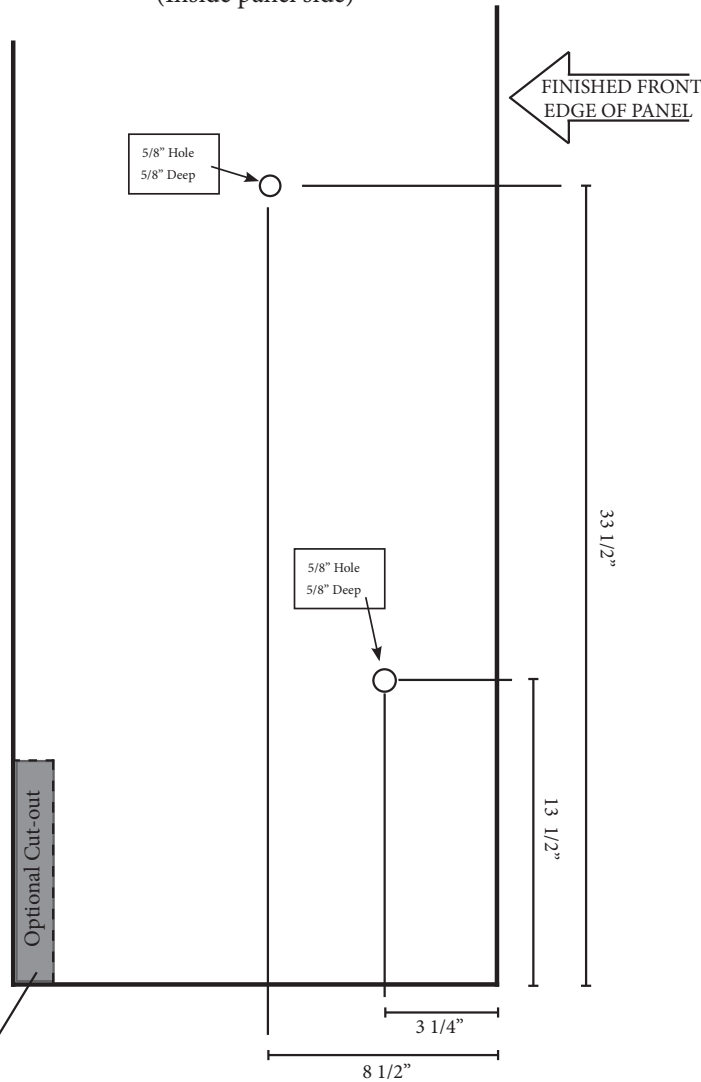

part navigation view

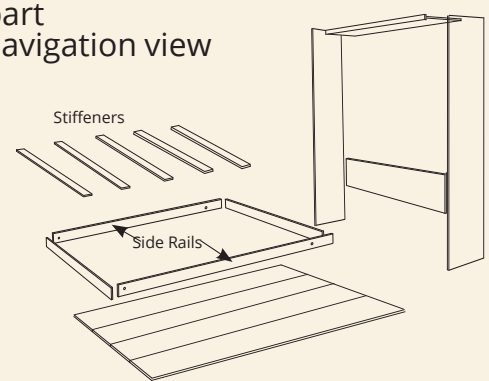

Optional Cut Out for Base Mold in Home

If there is a baseboard on the intended installation wall, there is a option to cut out the back bottom of the Side Board for easy installation. (Recommended)

Maximum cut out not to exceed 1" wide or 9" high. If baseboard exceeds these dimensions baseboard, or baseboard shoe molding will need to be removed during installation process.

Step 9

Milling Side Boards for Lift Mechanisms (cont.)

From the Hardware Box, locate one of the Upper Anchor plates and one of the Pivot Post. Note there are two of each, you will only need one of each for now.

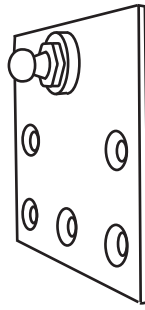

Upper Anchor Plate

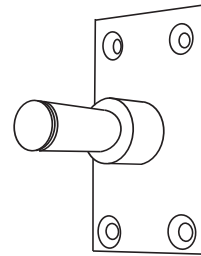

Pivot Post

Use the Upper Anchor plate as a template by placing the nut on the back of the Upper Anchor plate into the 5/8" hole in the side boards. Then drill through the Side Boards ONLY at the center lower hole of the plate - first with a 13/64" drill bit. Then remove the Anchor Plate and final drill through the Side Board with a 1/4" drill bit for proper hole size.

Use the Pivot Post as a template by placing the back of the Pivot Post into the 5/8" hole in the side boards. Then drill through the Side Boards ONLY at the UPPER two holes of the Pivot Post - first with a 13/64" drill bit. Then remove the Anchor Plate and final drill through the Side Board with a 1/4" drill bit for proper hole size.

Repeat on the opposite Side Board. Then place Upper Anchor Plate and Pivot Post back in the box to be installed later

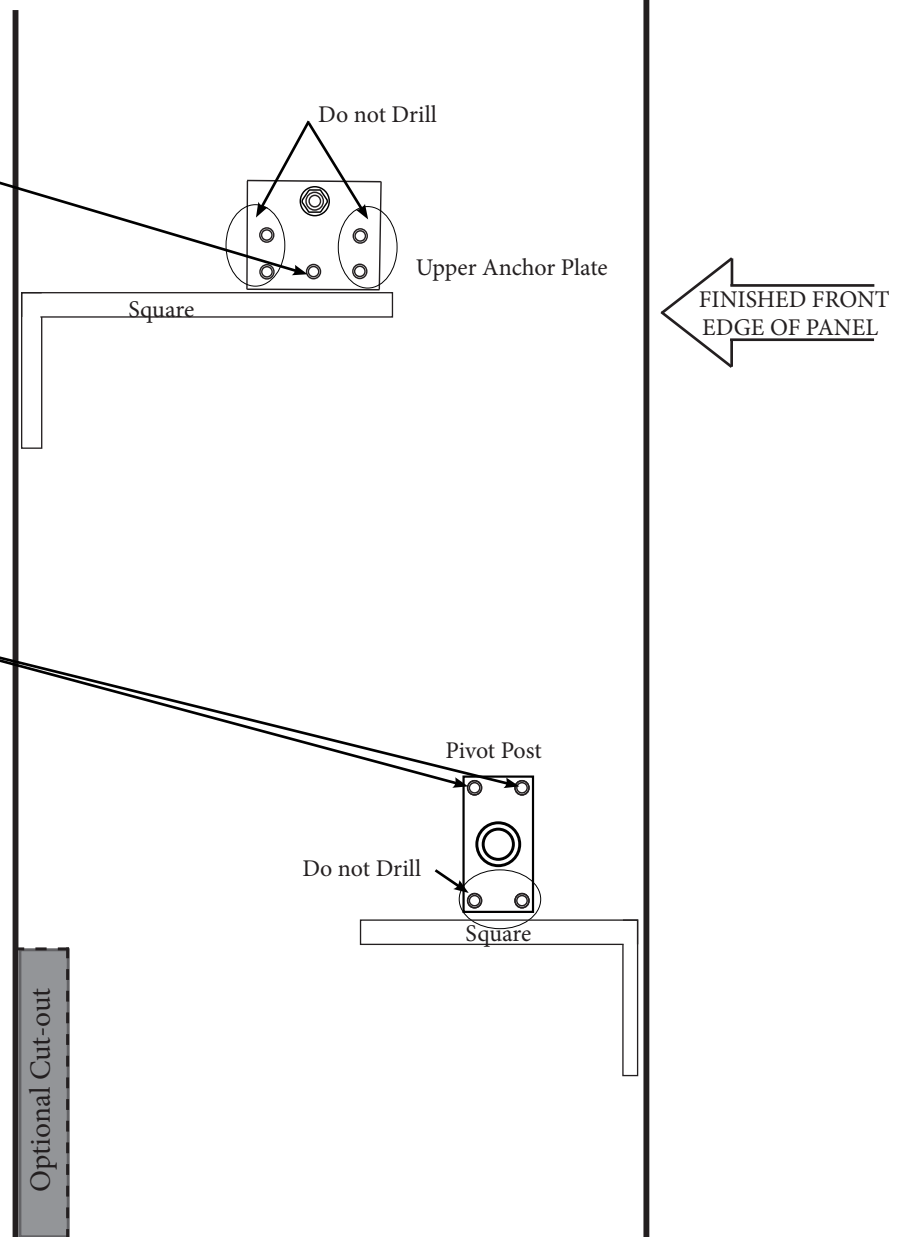

Finishing Diagram

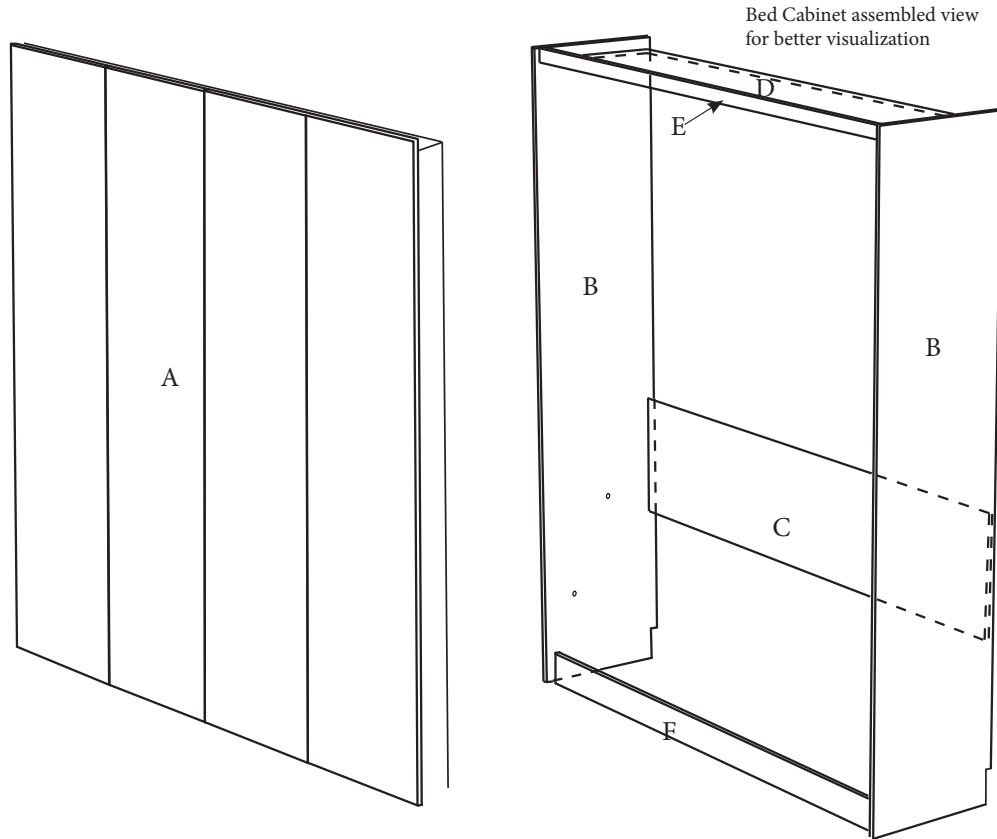





Part	Description	Finishing Notes
A	Face Panel	Face Panel is the front of the bed when it is closed. Apply finish to the face panel front, all edges (should be edge banded) and around the parameter of the back panel as well as the rails. Between the rails is where the mattress sits, finish if desired.
B	Side Board	Side Boards should have finish applied to both sides and the front edge. (Should be edge banded).
C	Headboard	Headboard should have finish applied to one side, top edge (should be edge banded). Finish back if desired but won't be visible.
D	Bridge Board	Bridge Board should have finish applied to one side. Finish opposite side if desired, but is not typically seen.
E	Top Fascia	Top Fascia should have finish applied to one side and edge banded edge. (should be edge banded on bottom edge).
F	Front Stretcher	Front Stretcher should have finish applied to one side and one edge. (should be edge banded).

Step 11

Installing Mechanism Components

Hardware and parts needed for next step:

 x 6	 x 6	 x 4	 x 8
M5 x 16 Machine Screw	M5 Barrel Nut	W4.8 x 19 Wood Screw	W4.2 x 18 Wood Screw

From Hardware Card #1

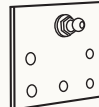
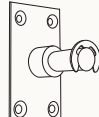
 x 2	 x 2
Upper Anchor plates	Pivot Points

Step 1:
Locate the left AND right Side Boards and install:

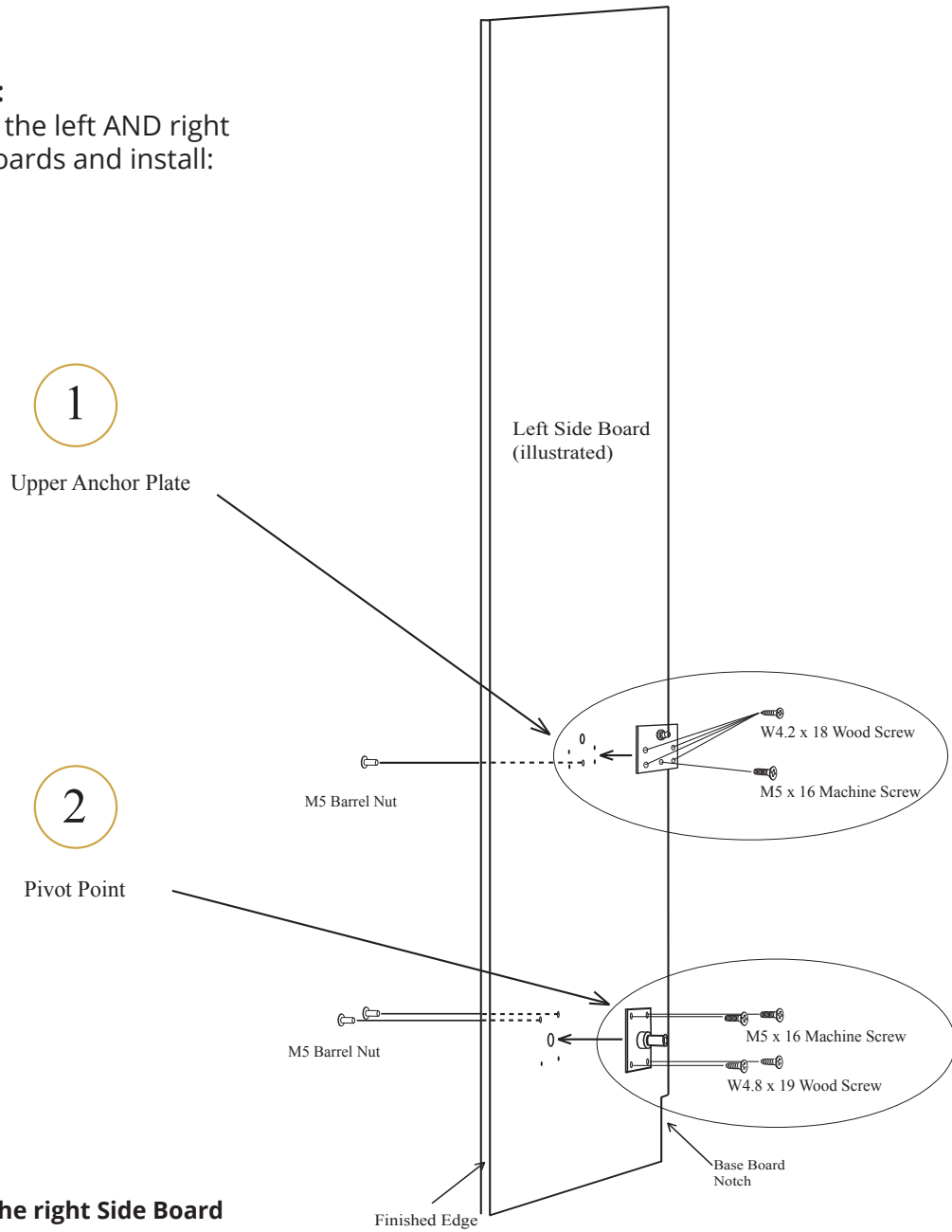

Repeat this step on the right Side Board

NOTE:

It is recommended that you dry fit (put together) the Cabinet Surround as illustrated in the next step. This will allow you to carefully place all of the cabinet surround parts prior to the final assembly. You then will need to disassemble the surround however the final assembly will go smoother if all the parts have been pre-installed.

Step 12

Installing Mechanism Components

1. Locate the mounting position of the Headboard marking the left and right Side Boards 22" from the floor and 1" in from the back edge of the Side Boards See Drawing 5 below. Use Corner Brackets to attach Headboard to Sideboards note that the Angle Bracket cannot protrude beyond the back of the Side Boards.
2. Use Angle Brackets to assemble Front Stretchers in positions shown in Drawings 7, & 8 (page 22-23). Use one bracket on either end of the Front Stretcher.
3. Attach Bridge Board as shown in Drawings 5, 6 & 8 (pages 22-23). Be sure back edge of the Bridge Board is flush with back of Side Boards and 1" down from the top of the Side Boards so it is flush with the bottom edge of the Top Fascia. The Top Fascia will cover the front edge of the Bridge Board.
4. Attach the Top Fascia to the front edge of the Bridge Board using Angle Brackets as shown in Drawing 5 & 8. Note the Top Fascia covers the front edge of the Bridge Board and is flush with the bottom. The Top Fascia should be 3/4" back from the front of the Side Boards.

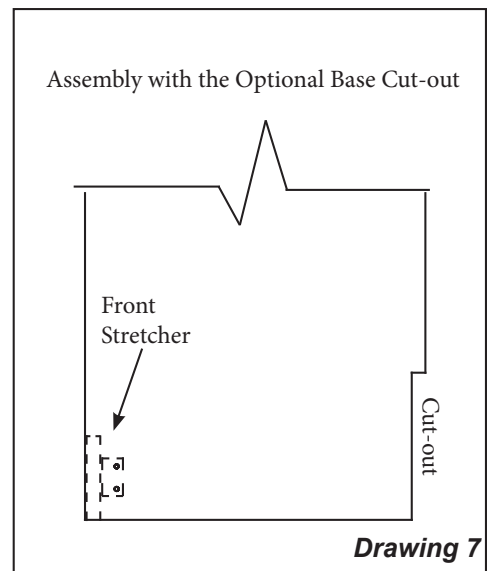
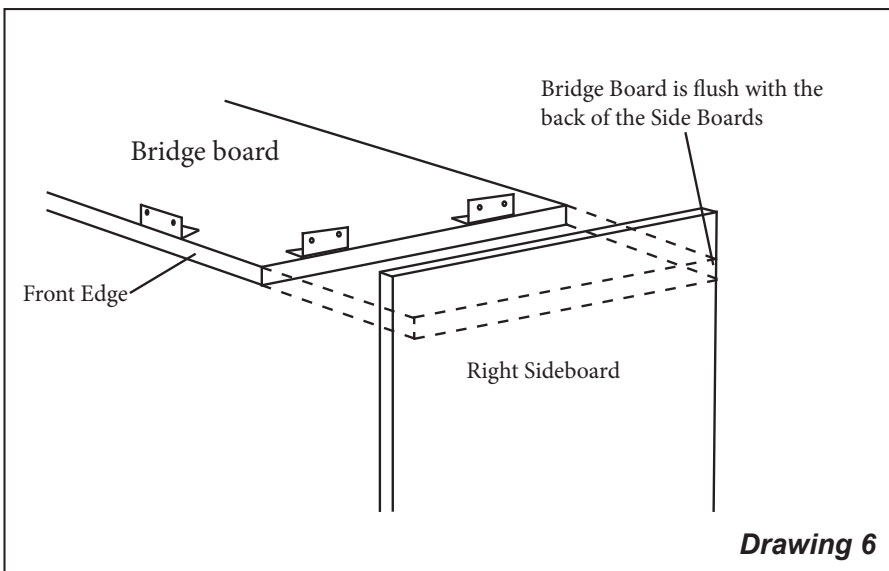
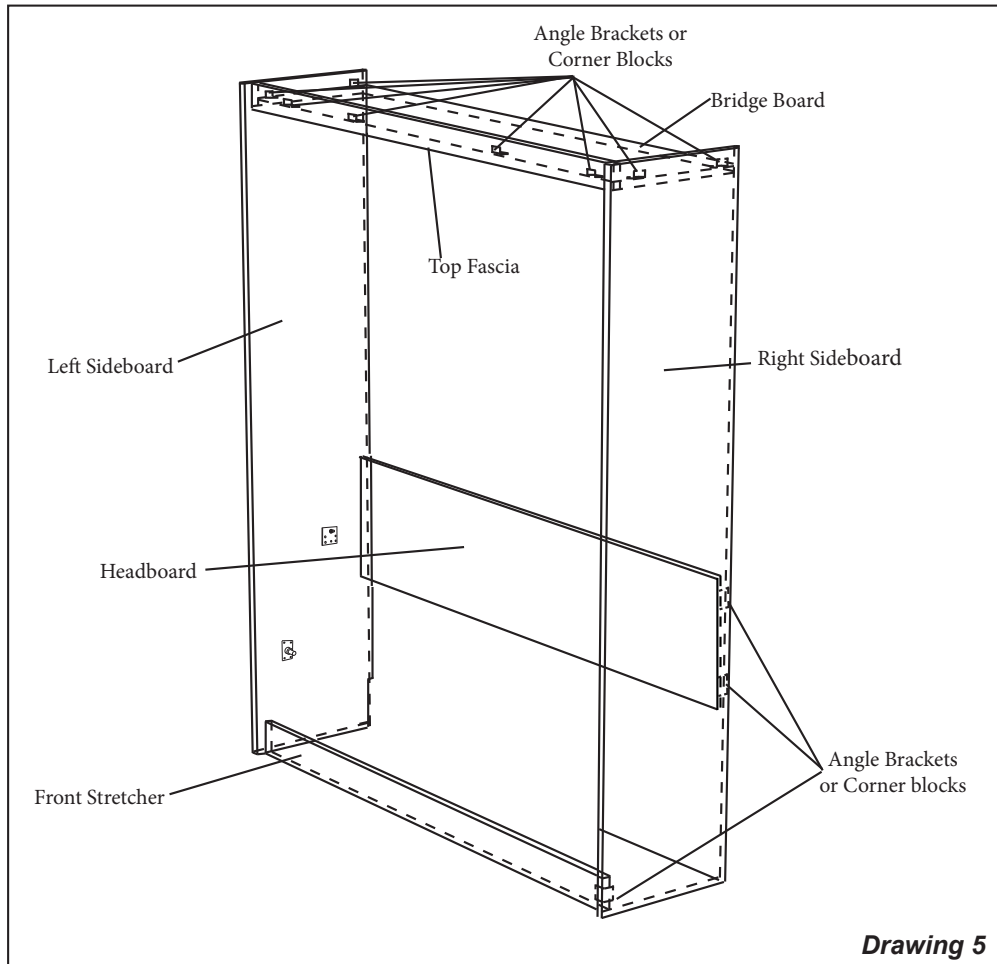

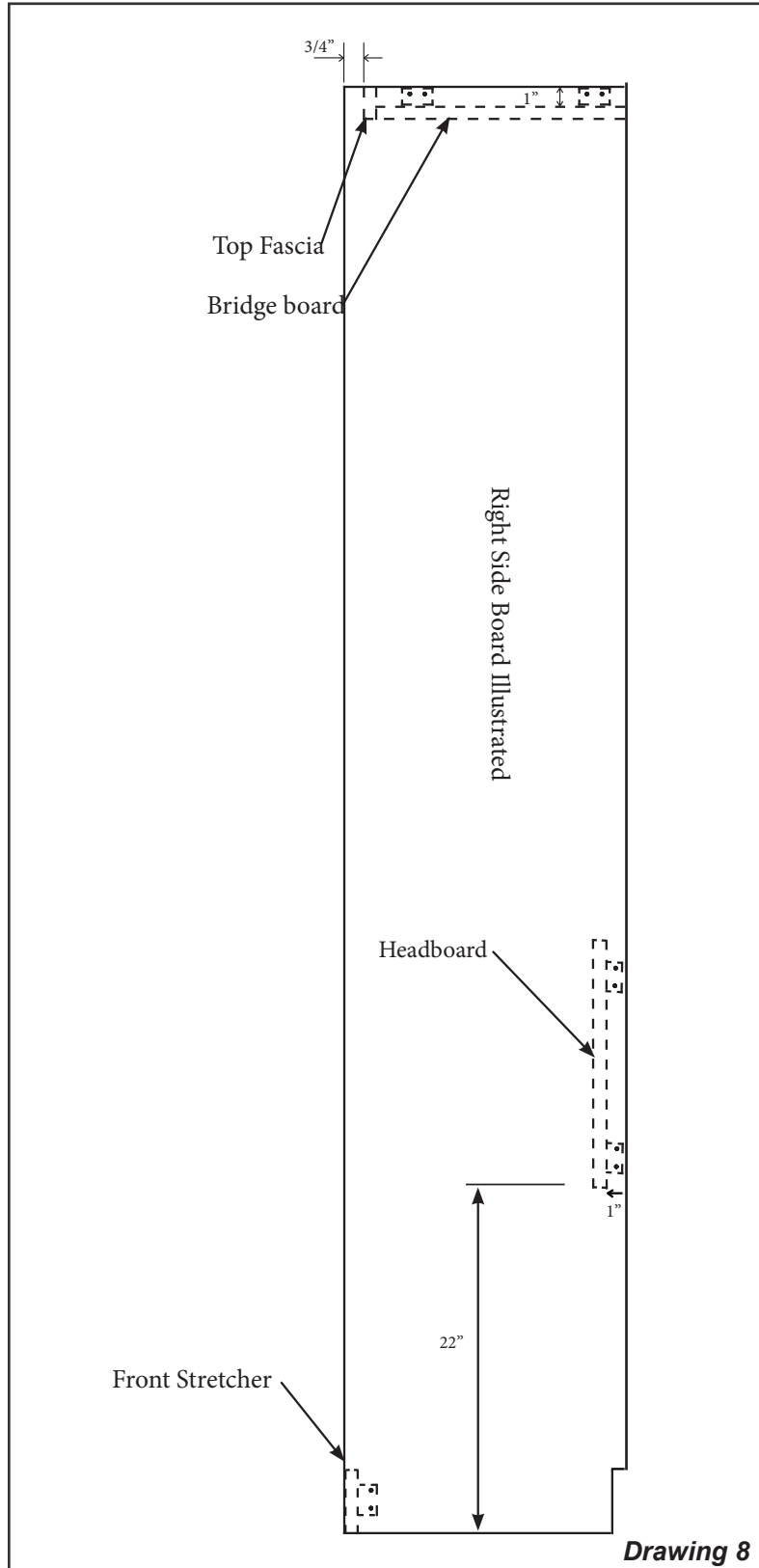

Step
13

Assemble Segmented Leg Rod

Assemble the Segmented Leg Rod using illustrations below.

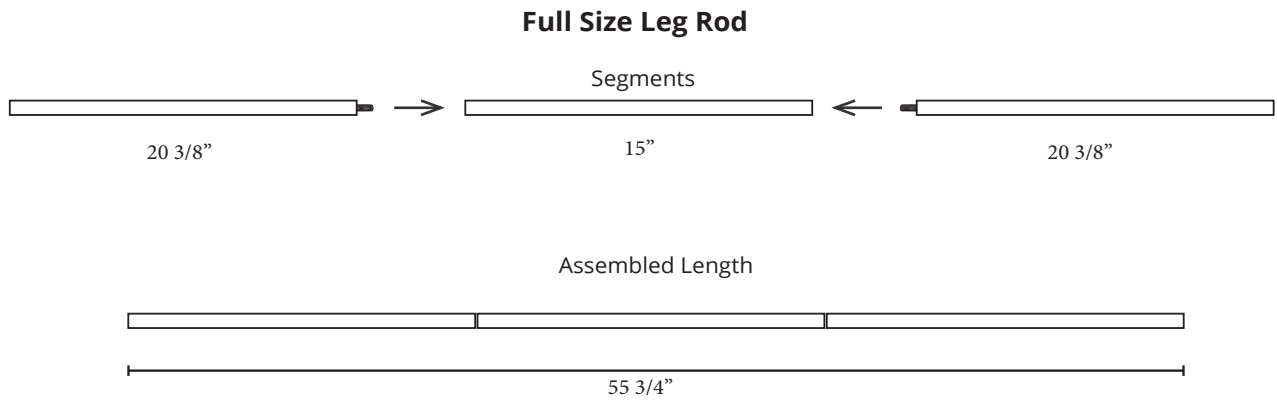

Step 14

Installing the Legs & Leg Rod

Hardware and parts needed for next step:

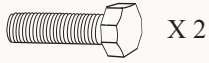

X 2

M5 x 40 Machine Screw



X 2

Star Washer

From Hardware Card #2



X 2

1 1/2 Nylon washer



X 2

1 1/2" x Flat Washer

Pre-installed on Legs

Attach the Leg to the Side Rails as illustrated below. Use 1 Nylon Washers on the out side of the Side Rail then a Flat Washer and Nut (pre installed on leg).

Position the segmented Leg Rod between the Legs. Place the Star washer on the M5 x 40 Machine Screw and tighten the rod in place.

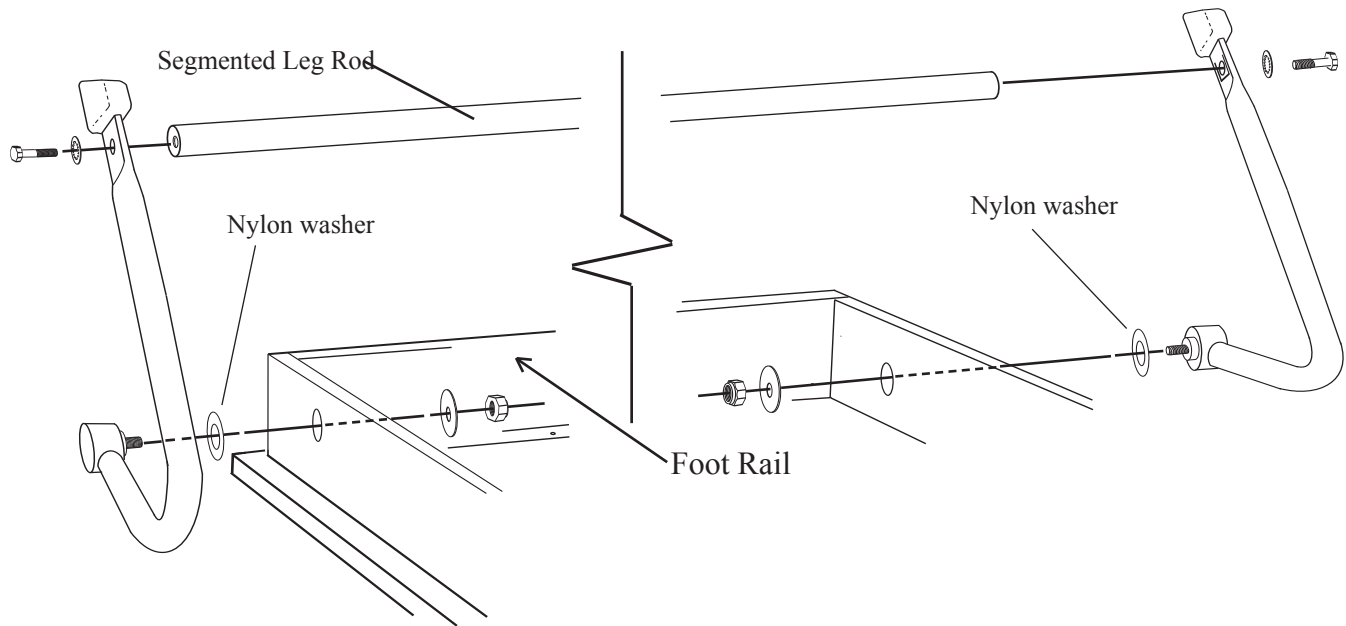

Step 15

Installing the Mechanism Hardware

Hardware and parts needed for next step:

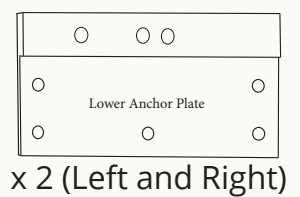
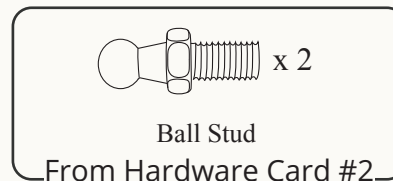
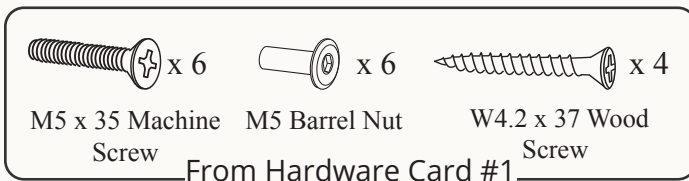

Thread the Ball Stud into hole #2 on both Lower Anchor Plates using a 1/2" wrench

! IMPORTANT:

IMPORTANT: BALL STUD MUST BE IN HOLE #2 FOR FULL SIZE BED OR MECHANISM WILL NOT WORK PROPERLY AND MAY DAMAGE THE PISTON.

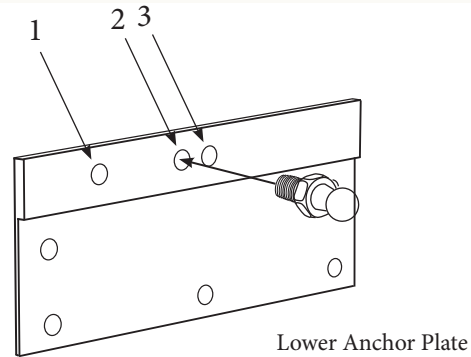

Place the Lower Anchor Plate in place on the Mechanism Support. Fasten it to the Side Rail using three M5 x 40 Machine Screws into Barrel Nuts. Then use two W4.2 x 37 wood screws in the remaining two holes.

! IMPORTANT:

THE LOWER ANCHOR PLATE ARROW MUST BE POINTING TO THE HEAD END OF THE BED AS ILLUSTRATED

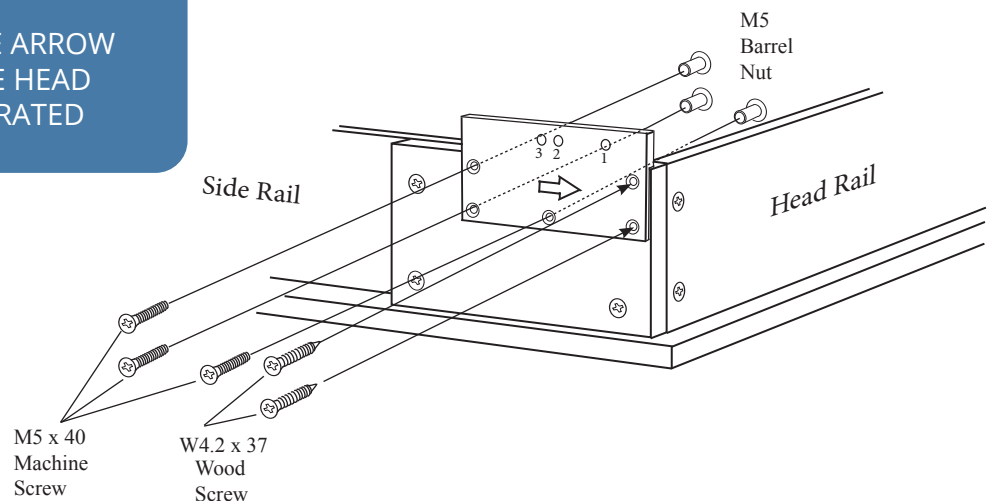

Repeat on left Side Rail

Step
16

Installing the Mechanism Hardware (cont.)

Hardware and parts needed for next step:

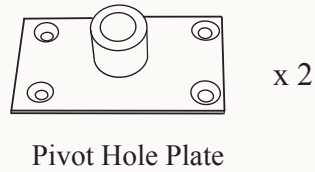
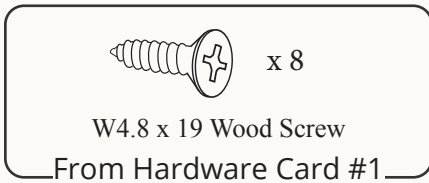

Insert the Pivot Hole Plates into the holes on the Side Rails from outside the Mattress box. Then use W4.8 x 19 Wood Screws to anchor them in place.

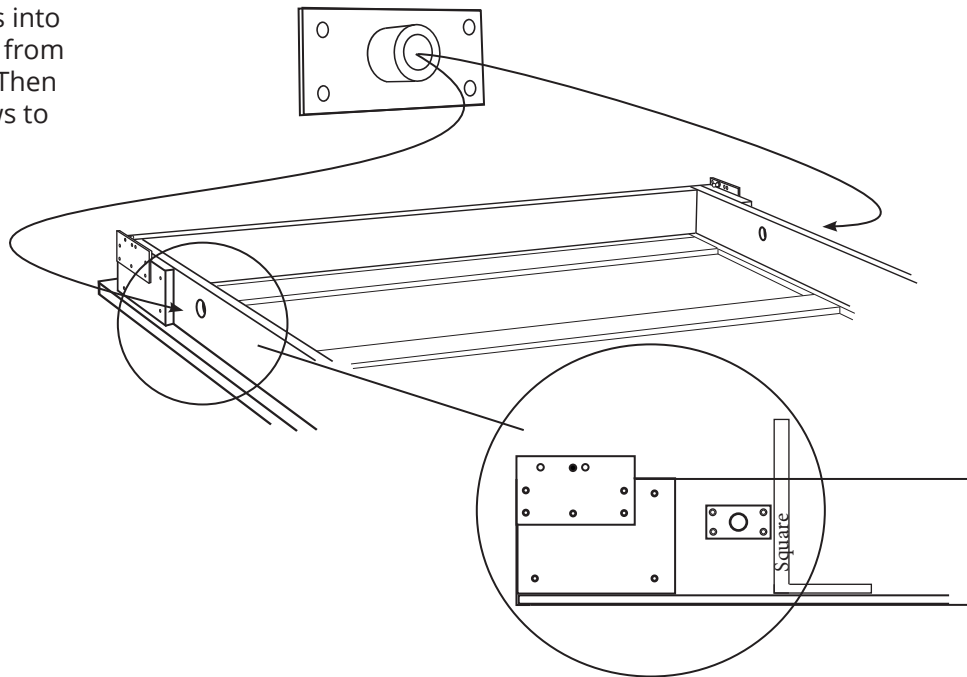

Step 17

Final Assembly

Final assembly and installation on the following pages should be done within the room in which the bed will be used.

TOOLS NEEDED

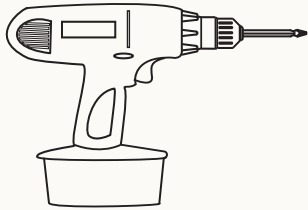

Cordless Screw Driver or Power Drill with Phillips bit



Pliers

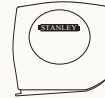

Tape Measure



Small Regular Screw Driver



#2 Square Tip Bit

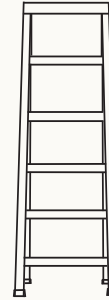

6' Step Ladder

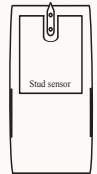

Stud Sensor

Position the Mattress Box and the right and left Side Boards face down on the floor with the bottom of the Mattress Box approximately 2.5 feet from the wall where the bed will be installed.

With a pair of pliers, remove the E-clips from the Pivot Posts on the Side Boards.

Slide the Side Board Pivot Posts through the Pivot Hole Plates in the Mattress Box as illustrated then replace the E-clips onto the Pivot Posts.

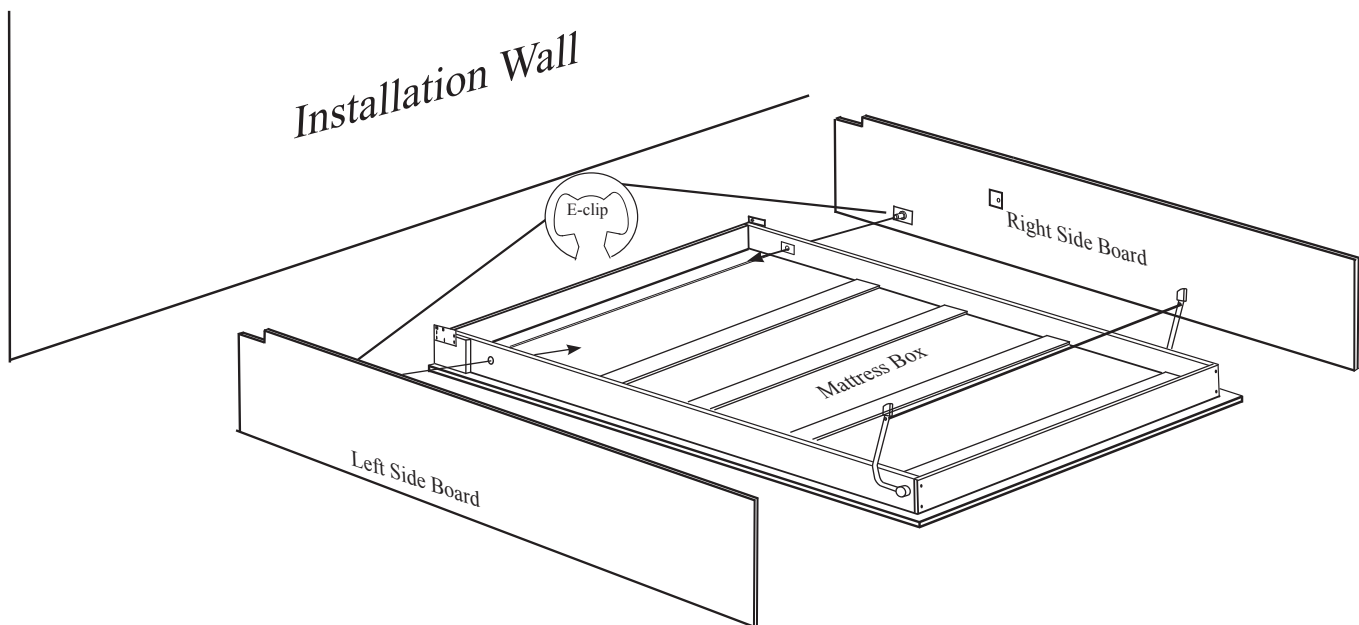

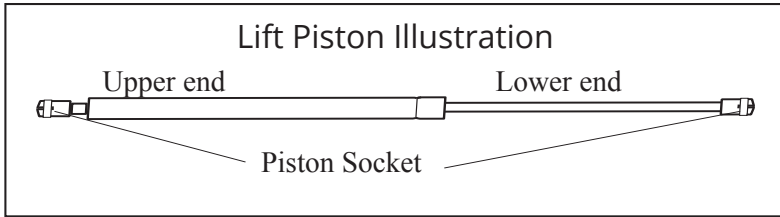

Attach the lower end of the Lift Piston (skinnier end) onto the Lower Anchor Plate on the Mattress Box by positioning the Socket of the Piston directly over the Ball Stud on the Anchor Plate and pushing them on. The Piston Socket will snap into place over the Ball. Repeat on the opposite side.

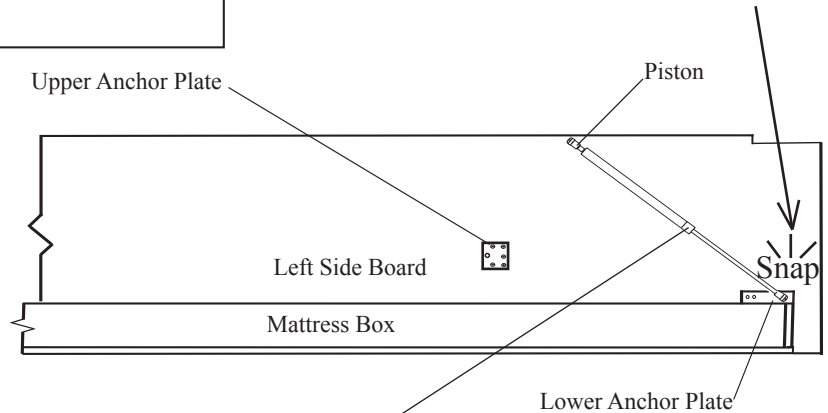

Two person step. One person will lift the Foot Rail end of the Mattress Box about 4 to 6 inches (Illustration 1) while the other person positions the Upper Socket end of the Lift Piston directly over the Ball Stud on the Upper Anchor snapping it into place when it aligns. The foot end of the Bed Box will need to slightly raise and lower to allow the Piston to line up and snap on. Repeat on the opposite side so both pistons are attached. (Illustration 2)

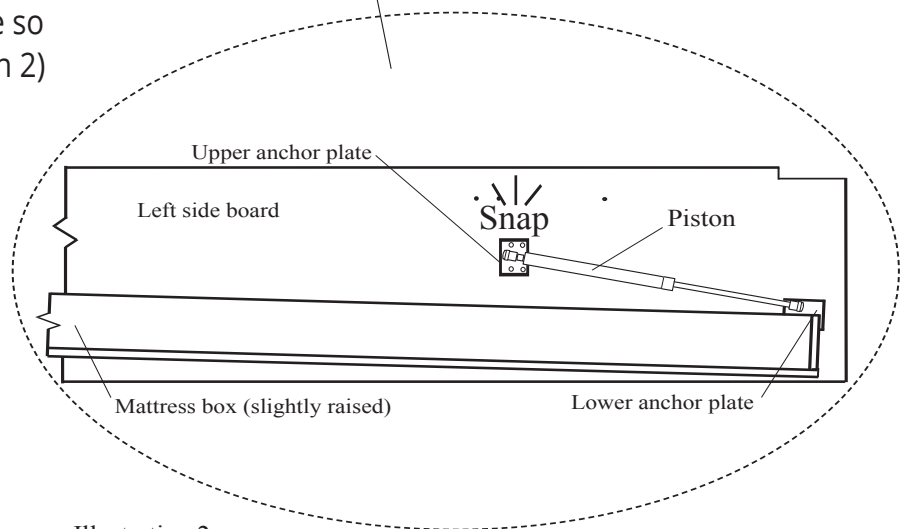
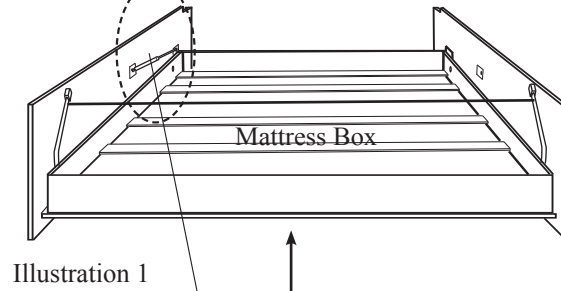

Step 19

Final Assembly (cont.)

Hardware and parts needed for next step:



Connect the Bridge Board to the Side Boards and the Front Fascia using Corner Brackets reinstalled after dry fitting in previous step. Place WARNING label on top of the bridge board.

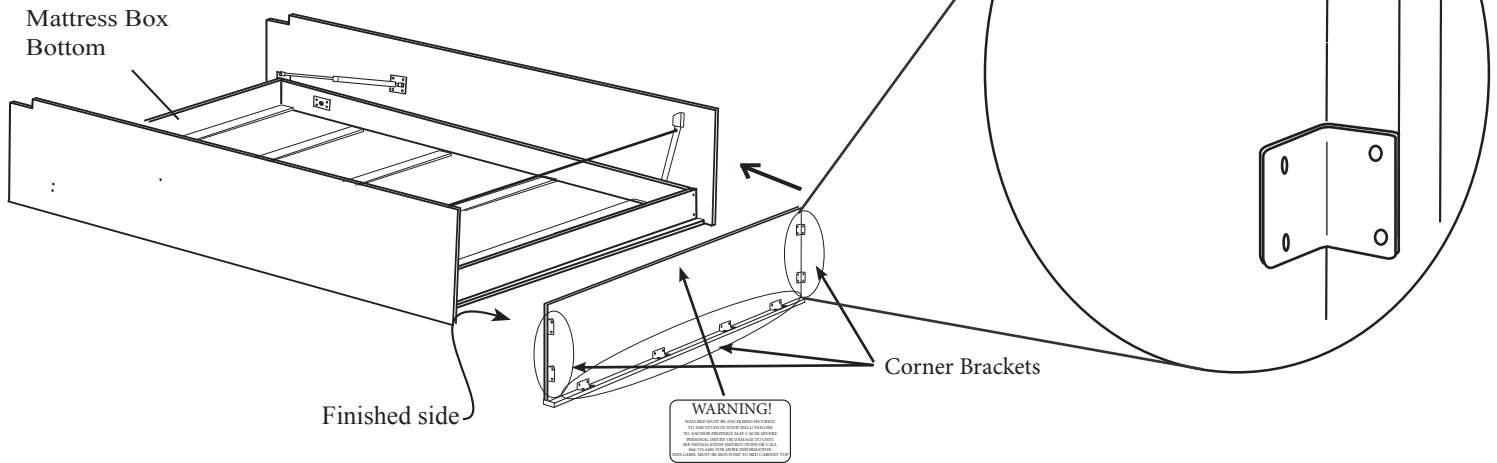

With the bed unit still lying face down on the floor the Headboard can be installed. **HAVE SOMEONE HELP WITH THIS STEP.** Slide the Headboard between the Side Boards and reinstall after Dry Fit. Headboard bottom should be 22" from the bottom of the side boards and 1" inside Side Board back (just enough so Corner Brackets do not protrude beyond Side Board back).

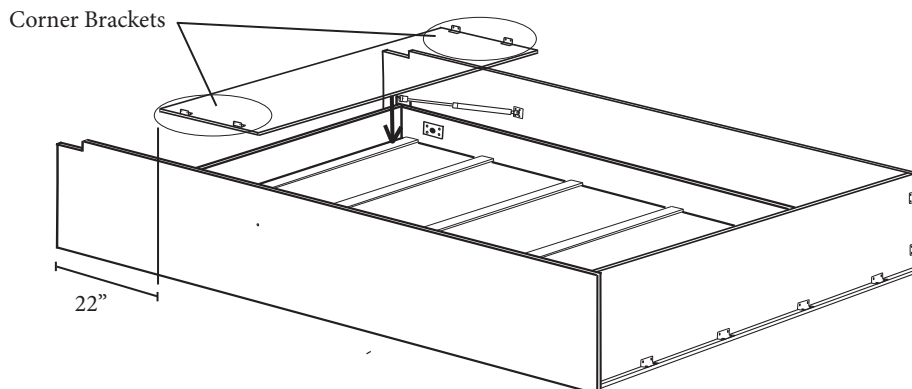

Step 20

Final Assembly (cont.)

Slide the Stretcher Board between the Side Boards at the bottom front of the Wallbed unit attach using Corner Brackets in the holes from dry fitting.

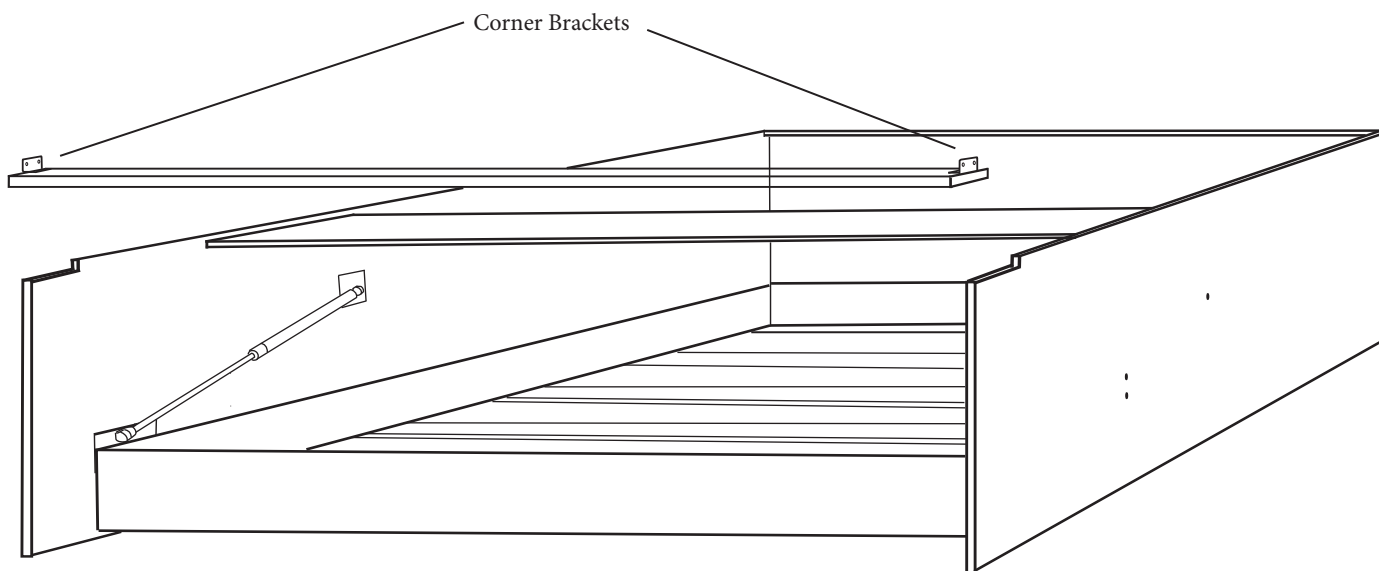

! HEAVY! 2 PEOPLE REQUIRED

THIS STEP WILL REQUIRE 2 PEOPLE. FROM THE TOP OF THE WALL BED UNIT LIFT IT UP TO THE STANDING POSITION IN FRONT OF THE WALL WHERE IT WILL BE INSTALLED

! IMPORTANT

SUPPORT THE BED FACE AS YOU LIFT SO IT DOES NOT OPEN AS IT IS BEING LIFTED.

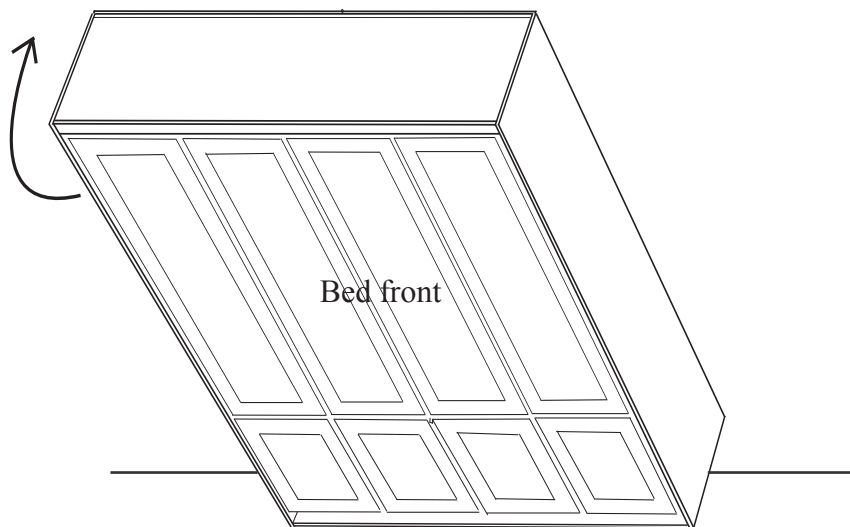

Step
21

Anchoring Bed to the Wall



WARNING! FAILURE TO PROPERLY ANCHOR THE BED CABINET COULD CAUSE SEVERE PERSONAL INJURY OR DEATH. CALL TECHNICAL SUPPORT AT 866-725-6401 IF YOU HAVE ANY QUESTIONS.

Hardware and parts needed for next step:

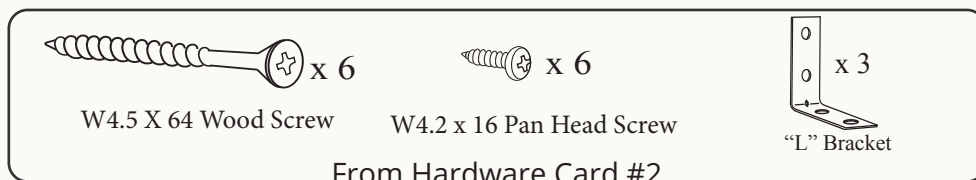

Using a Stud Finder locate and mark the studs in your wall behind the Bed Cabinet. Attach "L" brackets to the top, back of the Bed Cabinet using W4.2 x 16 Pan Head screws corresponding to where the studs are located in your wall. Now attach the "L" brackets to the studs in the wall using six W4.5 x 64 Wood Screws.

IMPORTANT

QUEEN AND FULL SIZE BEDS REQUIRE 3 STUDS, TWIN SIZE BEDS REQUIRE 2 STUDS. IT IS VERY IMPORTANT THAT THE BED CABINET BE ANCHORED SECURELY TO THE WALL. FOR TECHNICAL SUPPORT CALL 866-725-6401 TOLL FREE.

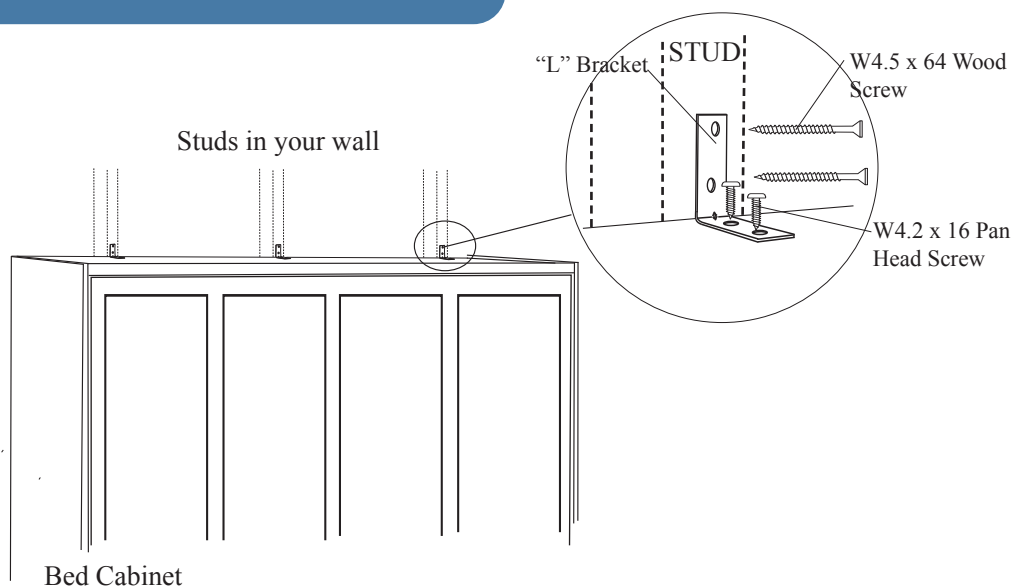

Check the gap alignment between Side Boards and the Bed Face. If the gaps look correct, skip this step.

If the gap is not correct, meaning that the Bed Front is too close to the Side Board (or even touching it) at the top on one side. It can be adjusted after the Bed unit is attached to the wall but it will require two people.

The procedure will require the bottom of the bed to be moved slightly to the left or right depending on which top corner is too close.

If the bed is too close on the top right side (as can be seen in the image to the right), for instance, the right side (bottom) will need to be shifted to the left slightly.

To do this, have one person push the bed at the bottom while the second person pulls on the opposite bottom side.

NOTICE:

Top corner of bed front is too close to side board on right side of bed.

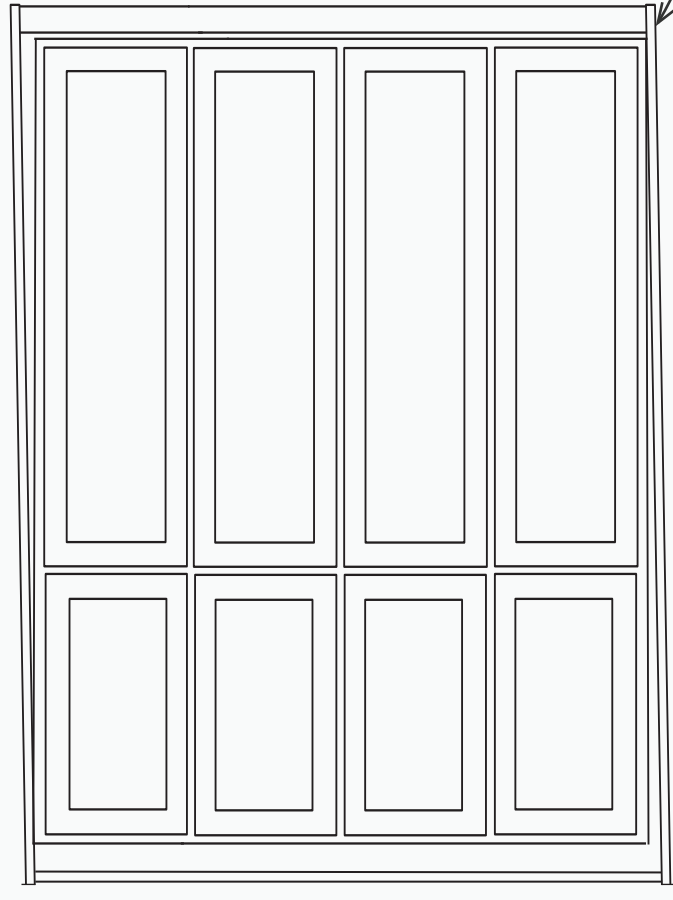

Push bed over at bottom to align gaps

Step
23

Installing Leg Stops

Hardware and parts needed for next step:

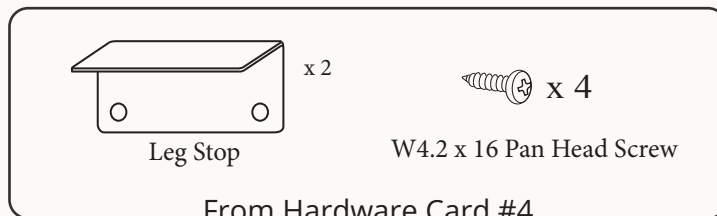

Open the bed and extend the Legs to a 90 degree angle. Once the legs are positioned correctly, attach the Leg Stop bracket to the Side Rail.

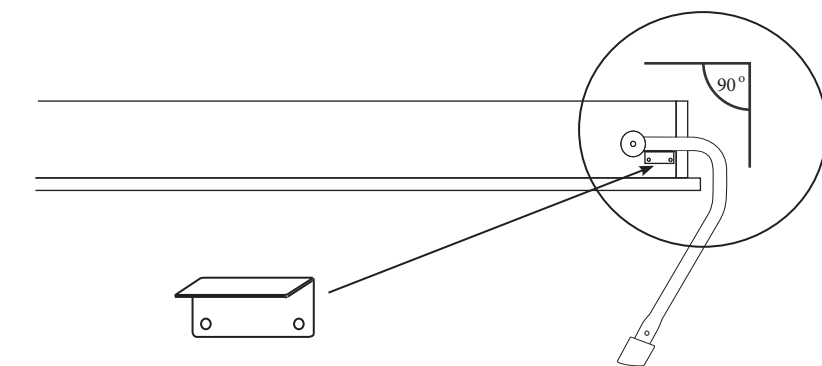

Step
24

Installing Handles (Supplied by Customer)

Measure and drill holes in the bed face where Handles are desired. Note Handles should be positioned more toward the top of the Bed Face for easier opening (Queen and King approx. 5 ft., Full and Twin 4' 6" from floor).

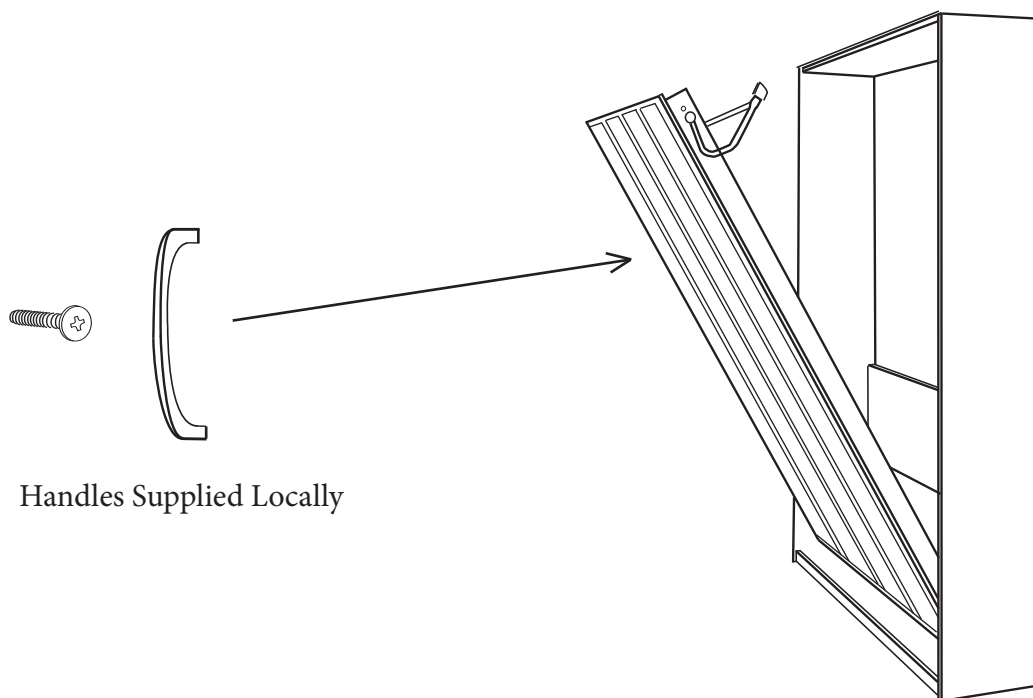

Enjoy Your Wilding Wallbed!